

CPV-connected ES for Multiple Services

- Choosing technology and dimensions of an ES for a solar power production site in Algarve, Portugal



Andreas Möser
Simon Siöstedt

Division of Industrial Electrical Engineering and Automation
Faculty of Engineering, Lund University

Acknowledgements

This master thesis is the final step for us, Andreas Möser and Simon Siöstedt, to finish our studies in Environmental Engineering at the Faculty of Engineering (LTH), Lund University. The thesis has been carried out for the department of Industrial Electrical Engineering and Automation (IEA) at Lund University in collaboration with the Portuguese renewable energy and innovation organisation, Enercutim, located in Lisbon.

Many kind people have helped us to complete this master thesis and we would like to express special thanks to our three supervisors namely, Jörgen Svensson, Nathalie Samovich and João Correia de Oliveira. Jörgen Svensson has been our supervisor at Lund University and always been very helpful and patient, especially with the simulations tutorials. Nathalie Samovich and João Correia de Oliveira have been our supervisors at Enercutim and provided us with valuable feedback on the thesis. Also, they have helped us gathering material to perform our simulations and literature study.

We would also like to thank Marc Rechter, João Santos, Tiago Henriques and Gonçalo Mendes who have supported us in our daily work at the office, with everything from gathering material to translating Portuguese documents.

Abstract

In this master thesis, the topic of energy storage connected to concentrator photovoltaic power production is assessed. The end goal is to propose the optimal energy storage technology and its sizing, regarding power and energy capacity, for an existing concentrator photovoltaic power plant. The plant is located in the province of Algarve in Portugal, the installed production capacity is 4.5 MW, and the average annual electric energy produced is 7 200 MWh. Services chosen to be provided by the energy storage, in falling priority, are ramping support, peak shaving and arbitrage. The energy storage system will pose as a demonstration project, contributing with knowledge to the field and promoting investment in novel energy technology. Also, as the penetration of intermittent renewable energy sources are expected to increase over the coming decades, the demand for services provided by energy storage systems will grow. To reach the objective of technology and sizing selection, a literature study combined with computer-aided simulations has been carried out. Also, an economic analysis of relevant technologies has been performed to help selecting the wisest option. For the simulations, measurements of direct normal irradiation have been used to calculate minute-by-minute power outputs. The validity of the calculated output was confirmed through comparison with real output data from the solar platform.

It was found that an energy storage based on the sodium-sulphur technology would be the preferred alternative. The proposed sizing was set at a rated power of 2.75 MW and an energy capacity of 1 MWh. With these characteristics, more than 98 % of the simulated extreme ramping events (changes in output over 10 % of installed capacity per minute) would be covered for. A general conclusion from the analysis is that to provide the service of ramping support, a rather high power rating is needed, while the required energy capacity is small. This means that out of the three chosen services, ramping support is the one dimensioning for the rated power. On the contrary, peak shaving and arbitrage are energy capacity intensive, thus, they are the dimensioning services for the energy parameter. It was also found that the arbitrage service, with the chosen energy storage dimensions, resulted in very limited gains in revenue. However, when the service is combined with peak shaving, it can instead be seen as a strategy to minimize losses in revenue.

Regarding technologies, it was early concluded that a mature option of battery energy storage was going to be chosen for our case. The sodium-sulphur technology was found to excel, from an economical standpoint, in cases where the required energy capacity is rather large. The lithium ion technology on the other hand is preferred when this dimension is kept small. A lead-acid battery was found problematic to combine with the services of peak shaving and arbitrage because of its limited ability to be fully discharged.

Table of Contents

Acknowledgement.....	i
Abstract.....	ii
Table of Contents.....	iii
Abbreviations.....	vi
1 Introduction.....	1
1.1 Purpose.....	2
1.2 Method - Overview.....	2
1.3 Delimitations	3
1.4 Outline of the Report.....	4
2 The Solar Demonstration Platform.....	6
2.1 Enercutim	6
2.2 Area and its features	6
2.3 CPV Power Production.....	7
2.3.1 CPV Installation at the SDP	7
2.3.2 Concentrator Photovoltaic (CPV).....	9
3 Energy Storage and Service Overview	12
3.1 Regulatory Environment.....	12
3.1.1 Regulatory Environment in the Future	12
3.2 Technology	14
3.2.1 Overview of Energy Storage Technologies	14
3.2.2 Early Discarded ES Technologies	17
3.2.3 Review of Possible ES Technologies for the SDP	21
3.3 Services.....	24
3.3.1 Overview of Services Provided by Energy Storage	24
3.3.2 Summary of Requirements for the Different Services.....	30
3.3.3 Discarded Services	30
3.3.4 Review of Possible Services for the SDP	31
3.4 Investment Environment.....	34
3.4.1 LCOE, Cost/kW and Cost/kWh of BESS Today and in the Future.....	34
3.4.2 Overview of Service Values Today and in the Future	38

3.5	Literature and Case Review	39
3.5.1	Existing PV, BESS and Service Combinations	39
3.5.2	Comparative of Case Studies	39
4	Design Method – Simulation	42
4.1.1	Method for BESS Sizing.....	42
4.1.2	Overview of BESS Control Strategy.....	44
4.1.3	Building the Model	45
4.1.4	Input Data	47
5	Result of Simulations Using OpenModelica.....	51
5.1	Ramping Support.....	52
5.1.1	Base Case	52
5.1.2	Sensitivity Analysis.....	56
5.2	Peak Shaving.....	57
5.2.1	Base Case	57
5.2.2	Sensitivity Analysis.....	58
5.3	Electric Energy Time-Shift (Arbitrage)	59
5.3.1	Base Case	59
5.3.2	Sensitivity analysis	61
5.4	Design Proposal for Combined Services	61
5.4.1	Base Case	61
5.4.2	Dimensioning.....	64
5.4.3	Sizing Sensitivity Analysis.....	65
5.4.4	Arbitrage Analysis.....	66
5.4.5	Capital Cost Analysis.....	67
5.4.6	Technology of Choice	67
5.5	ESS Expansion Options for a Growing SDP	68
6	Discussion	70
6.1	Evaluation of the Report.....	70
6.1.1	Choice of Technology	71
6.1.2	From Single Service One Day to a Full Month Combined Service Simulations	72
6.1.3	Regulatory Ramp Rate Limit Interpretation	72
6.1.4	Adjusted Peak Shaving Level During Higher Output Months	72

6.1.5	Arbitrage Revenue	73
6.1.6	Arbitrage Discharge Control	75
6.1.7	Control Strategy for Minimum Output	75
6.1.8	DNI-Based Output Data Variations Compared to CPV Output	75
6.1.9	DNI-Based Output Data Generally Compared to Real Output Data	76
6.1.10	Additional Services the BESS Could Provide	77
6.1.11	Economy	78
6.2	Uncertainties and Limitations.....	79
6.2.1	Changes in Regulations.....	79
6.2.2	Technology Breakthrough	79
6.2.3	Limitation of Data and Model Used for Simulations	79
6.2.4	Cost Intervals	80
6.2.5	Data Errors and Sizing for Ramping Support	80
6.3	Follow up Research.....	80
7	Conclusion	82
8	References	83
9	Appendix.....	90
9.1	Appendix A	90
9.2	Appendix B.....	91
9.3	Appendix C.....	91

Abbreviations

AC	Alternate Current
BESS	Battery Energy Storage System
CAES	Compressed Air Energy Storage
CPUC	California Public Utility Commission
CPV	Concentrator Photovoltaic
DC	Direct Current
DESS	Distributed Energy Storage System
DSO	Distribution System Operator
EASE	European Association of Energy Storage
ESA	Energy Storage Association
EDP	Energias de Portugal. The local Distribution System Operator.
ES	Energy Storage
ESS	Energy Storage System
ETE	Electricity-to-electricity
GHG	Greenhouse Gases
i.c./min	Installed capacity per minute. The abbreviation is used together with ramping support.
IEA	International Energy Agency
IRENE	International Renewable Energy Agency
LCOE	Levelized Cost of Electricity
Li-ion	Lithium-ion Battery
NaS	Sodium-Sulphur Battery
Ni-Cd	Nickel-Cadmium Battery
OpenModelica	Modelling tool used to perform the simulations in this thesis
PHS	Pumped Hydro Storage

RE	Renewable Energy
REN	Redes Energéticas Nacionais. The Transmission System Operator of Portugal.
RES	Renewable Energy Sources
Resolution	Time resolution of measurement data
RTE	Round Trip Efficiency
SDP	Solar Demonstration Platform
SMES	Super Magnetic Energy Storage
Tracker	Solar power collecting unit containing the CPV models, tracking the sun
TSO	Transmission System Operator
UPS	Uninterruptible Power Supply
VRB	Vanadium Redox Battery
Energy	Power over time expressed in [Wh], [kWh], [MWh], [GWh]
Power	Energy per second expressed in [W], [kW], [MW], [GW]

1 Introduction

A secure and affordable supply of energy is today a critical building block for a positive development of society. As of today, the world population continues to grow, while the overarching societal aim of increasing quality of life should apply to anyone. However, an increasing population and increased quality of life does not per definition imply a growing energy demand. Energy efficiency measures constitute a central and important part in energy planning, though it is not likely that these measures will keep up with the increasing demand. According to a forecast created by the International Energy Agency (IEA) the world demand for energy will grow with nearly one third of today's proportion, between 2013 and 2040. The demand for electric energy, constituting one section of the energy palette, is forecasted to grow by 70 % over the same time period (IEA, 2015a).

In parallel with a growing energy demand, a decrease in the use fossil fuels is of absolute importance. According the IEA's 450 Scenario¹ the energy-related emission of greenhouse gases (GHG) have to be reduced to from today's 32 to 25 gigatone annually by 2030 (IEA, 2015b). It is critical to limit the released amount of these gases to the atmosphere as fast as possible, to minimize the anticipated consequences of climate change. Many European countries have already agreed on the target of 20 % reduction in GHG emissions compared to levels of 1990 (European Commission, 2011).

The alternatives that are looked to, to replace fossil fuels, are renewable energy sources like biomass, wind and solar power. This is shown in the growing installed capacity of renewable energy sources (RES), which on a European level, has doubled between the years 2004 and 2014 (reaching 16 % RES gross final consumption of energy in 2014) (European Commission, 2016). A large part of this increase is attributed by new wind and solar power installations (European Commission, 2015). This trend is likely to continue as the Renewable Energy Directive commits the EU to reach 20 % share of renewable energy in gross final energy consumption by 2020, compared to 11 % in 2012 (EEA, 2015).

Wind and solar-based power generation is strongly weather dependent. Greater installed capacity of these power sources in the same system makes energy planning a more complex task. Furthermore, these setups demand a more agile and flexible energy system as a whole. When solar or wind recourses unexpectedly drop in production, other units will have to make up for this loss in capacity (disregarding large scale demand side response/management). Also, as an owner of wind or solar-based power production, being unable to plan at what time and price the electricity will be produced and sold is a draw back, when special feed-in tariffs are not offered.

One interesting solution to the mentioned problems, and others that will be discussed further on, is the implementation of an energy storage system (ESS) on grid level. A solution with this approach could house a wide palette of services that could benefit both the owner of intermittent energy sources and the electrical grid owner.

¹ Limiting the atmospheric level of GHG to 450 ppm CO₂-eq, likely to limit global temperature rise to 2°C above pre-industrial levels by the year 2100.

One specific site that hopes to benefit from the implementation of an ESS is the Solar Demonstration Platform (SDP) in Algarve, the southernmost province in Portugal. Algarve enjoys among the best direct normal irradiation (DNI) resource in Europe (GeoModel Solar, 2014). In the east interior of the region the private non-profit organization Enercutim operates a platform for electricity production from solar. The technologies used are three types of concentrator photovoltaic (CPV) and the first units started feeding energy into the grid in 2013. The organization has taken the decision to implement an ESS on their site to demonstrate its possibilities.

With a forecasted continued growth of intermittent renewable energy sources it is of great interest to examine what benefits an ESS can offer, implemented at a specific site of intermittent electrical power production. Taking into account that the ESS will be connected to a grid with fewer units of predictable fossil fuels, this makes the question even more interesting. Predictions state that the amount of ESSs will increase drastically the next 10 years (Navigant Research, 2014). Equally important is the analysis of technology choice and sizing with respect to the prioritized services at the Algarve site.

1.1 Purpose

The purpose with this master thesis is to provide Enercutim with a decision basis on the most appropriate ESS, optimized for the production of the Solar Demonstration Platform current capacity, its projected growth and for valuable services that could be provided to the plant owner and the electrical grid. Furthermore, the analysis will in general terms connect ESS functionalities to business cases and drivers for adding storage.

The following questions will be discussed throughout this report:

- What design and dimension of an ESS is appropriate related to provided services to the grid?
- What services can a specific ESS provide to the grid and the Solar Demonstration Platform?
- What are the economic interests to install an ESS for both the grid operator and the provider of the ESS?

1.2 Method - Overview

To answer the formulated questions, the chosen method for this master thesis consists of four overall parts; literature overview, literature study, data management and simulations. The used method was defined early in the work process. The only change that was made along the way regarding the method, was the part added for data management. This was added because of the limitations of available data.

Literature Overview

In order to both give the reader an understanding of important aspects of ESSs and to determine the most appropriate technologies and services provided by energy storages (ES), the literature overview is constructed as a filter. To structure the literature overview in this way means that all of the common ES technologies and services are presented, followed by parameters that separates them. In the end this filters down to the best-suited ES and services for this specific case.

Because of time limitations it would not be possible to perform a report considering every available service for every possible ES. However, the aim was to provide a clear picture of why some ES and services are discarded and why the remaining is chosen.

Literature Study

With the filtering process completed, a literature study was made in order to determine the most appropriate way to perform the simulations and to interpret the results. Different reports dealing with ESSs in combination with the chosen services were reviewed and both the method and their result are compared to each other. The result of the literature study will provide simulation options, formulas and key parameters to validate the result of this thesis with.

Data Treatment

Data treatment was added to the method after it was known that no real production data with a resolution below one minute could be acquired. With acquired data for DNI from September 2015, further data was gathered to calculate the equivalent CPV output from the SDP.

Excel was used to perform calculations, in order to transform DNI data values to electricity production for every minute. The formulas were provided by Enercoutim and were used together with weather data and performance data from the manufactures of the CPV modules.

Simulations

To perform the technical simulations for the ES in combination with different services, the simulation program OpenModelica was used. With help from the literature review and from our supervisor, a model over the ES, the local grid and the generation units at the SDP is built. The simulations are executed on several second basis, and provided an insight in how the different components within the model affect each other. The simulation results are the main source for the result chapter, which lay the basis for the discussion.

Other simulation programs than OpenModelica could be used for the same purpose. The reasons why OpenModelica was used were both because of its ability to generate a result in high resolution (sub second if needed) but also because our supervisor already had good knowledge in this program. The latter was the settling argument.

1.3 Delimitations

- Since the site for the ESS implementation is decided there are geographical limitations for the implementation of certain ESSs. Thus, large scale technologies like compressed air energy storage (CAES) and pumped hydro storage (PHS) are not considered.
- The ESS will be connected to the grid and will not be part of an autonomous micro grid i.e. constituting the only generating unit for the grid. The thesis is only looking at grid connected ESSs.

- Considered technologies that are at market today and not on the laboratory stage, even if predictions indicate that they could be available in the near future. Only looking at mature/close to mature technologies.
- Only electricity-to-electricity energy storage technologies are considered in this study i.e. not power-to-gas-grid or power-to-heat.
- Only looking to provide decision basis on battery technology and dimensions, not considering advanced control system, power electronics, converters, switchgear, communication systems, safety systems or other equipment.
- The report is treating battery technologies in terms of technology families e.g. Lead-acid or Li-ion family and not every existing battery technology within each family.
- Not considering the combination of two or more ES technologies. The situation with CPV and ESS in the same system is already rare and relatively unexplored. Adding another level of complexity is not necessary.

1.4 Outline of the Report

The master thesis consists of 9 chapters. The chapters 2 to 7 are explained in further detailed below. Chapter 1, 8 and 9 are simply the introduction, references and appendix.

Chapter 2

This chapter explains the area of interest for the ESS, the internal grid and how the production of electricity is arranged. This chapter also explains the basics about how CPV-cells work, how clouds interfere in the power production, and what advantages and disadvantages this technology has compared to normal PV-cells.

Chapter 3

Chapter 3 consists of five subchapters that are together making up a filter to determine the most appropriate ESs and services for the SDP. The regulatory environment presents how integration of RE and ES is regulated today and how it is discussed for the future. This subchapter is followed by a section explaining different ES technologies, and services provided by ESs. Both of these chapters start with an overview of every commonly available technology and service. Thereafter it is explained why some options are discarded. Both subchapters end with a review of the possible technologies and services for the design proposal for the SDP.

Chapter 3 also presents the investment environment for services and technologies, and a case review of existing ESSs. The investment environment present values and cost of technologies and services today and forecast for the future. An estimation of the cost of the possible ESs is also presented in terms of LCOE and capital cost in EUR/MWh and EUR/MW respectively. The case review presents what ESs are already implemented today, what services they provide and a comparison between different sites.

Chapter 4

The method for designing the ES for the SDP is presented in chapter 4. This section starts with evaluating different sizing methods from other research. By introducing a flow chart over how the ES is chosen to be controlled, the operating strategy is explained. Thereafter an explanation follows of how the OpenModelica model is designed. A presentation and a discussion about the used input data and the relevance of it wraps up this chapter.

Chapter 5

Chapter 5 presents the result of the performed simulations. First, a base case and a sensitivity analysis is shown for each individual service, providing detailed graphs and tables to illustrate the result. A final design proposal is then presented for the base case with the combined services and the priority between them. A sensitivity analysis is performed at key parameters together with an analysis of the capital cost for the different cases. The chapter ends with the result and analysis regarding how an ES could be dimensioned in case of an increased installed capacity in the future.

Chapter 6

The discussion of the method, result, uncertainties, limitations and follow up research are presented in this chapter. An evaluation of the report constitutes the greater part of this chapter where the method first is discussed followed by the technology of choice, the different services, economic parameters and additional services. Further discussion in terms of uncertainties and limitations of the thesis is then conducted and the chapter ends with suggestion of research that can be performed where this thesis ended.

2 The Solar Demonstration Platform

2.1 Enercutim

Enercutim is a private non-profit organisation with its head quarters in Lisbon, Portugal. Their main goal is to promote, develop, and support renewable energy projects and to attract and advance further technology developments, especially within the solar energy sector. This goal is reached, in part, through the Martim Longo Solar Demonstration Platform (SDP), which is located in the Alcoutim municipality in the southern province of the Algarve, Portugal.

Enercutim is active in a number of European and International Research and Innovation programs. Some of these activities imply the participation in European calls under the ERANET, KIC Innoenergy and Horizon 2020 programs.

2.2 Area and its features

The SDP is located in Algarve, the most southern province of Portugal. Martim Longo is the closest village to the SDP, and the municipalities main city of Alcoutim, is located about 30 km to the east. The Martim Longo area receives among the highest quantities of direct normal irradiation (DNI) in Europe. In average, the site receives around 2000 kWh/m² in annual DNI. This is twice as much as for the Lund area in Sweden (GeoModel Solar, 2014).

The total land area claimed by the power-producing units, including spacing area in between them, amounts to ca. 16 ha. This area is comparable with the size of 20 soccer fields. The topography of the site and its surroundings is relatively flat with no major height differences to consider. The land area in the proximity of the site is mostly used for agricultural purposes (Enercutim, 2016b). The topographical features of Portugal and the area of interest are shown in Figure 2-2 below.

The natural gas grid in Portugal extends only along the major part of the west coast and through the central parts of the country. Consequently, this part of the Algarve lacks the possibility to connect to any natural gas infrastructure (IEA, 2014b).

In Portugal in general, heat demand over the year is limited. For the housing and service sector it exists only during some winter months. This demand is even less in the southern part of the country. Also, no major heat consuming industry is located in the vicinity of the SDP.

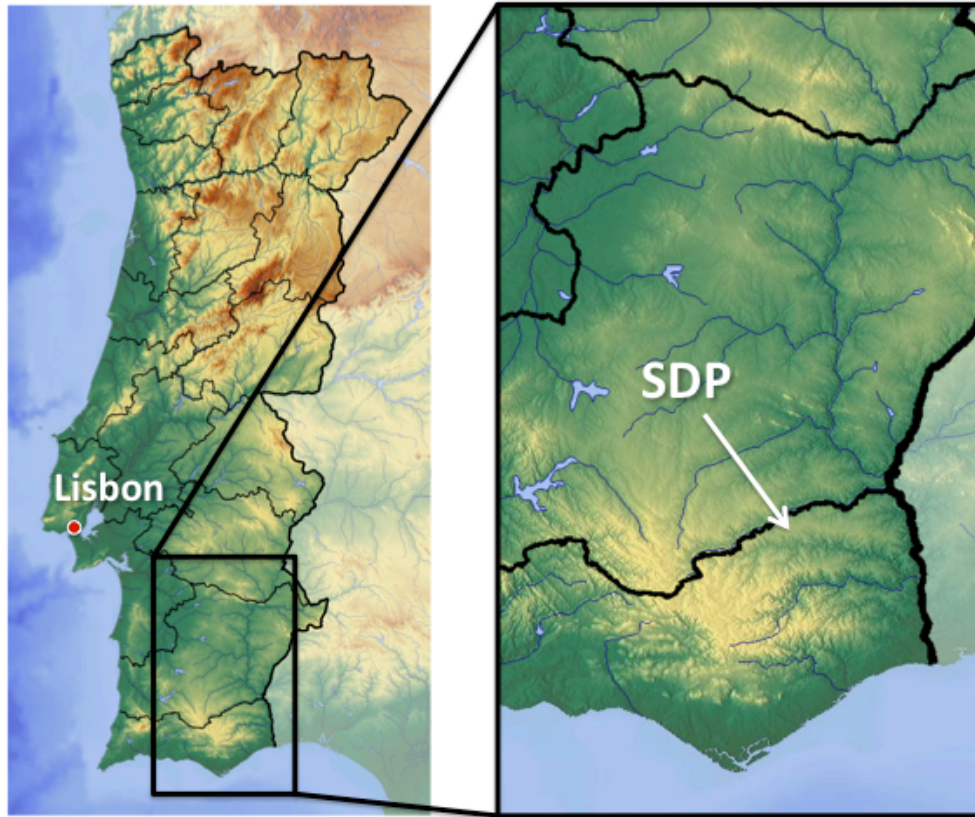

Figure 2-1. Topographical map of Portugal with SDP marked out (Brains, 2012). Picture edited by author.

2.3 CPV Power Production

2.3.1 CPV Installation at the SDP

The total installed power production capacity at the SDP is 4.51 MW, which give a peak power output of about 4 MW. This gives an average generation of about 600 MWh per month and 7 200 MWh electricity per year. The installations are split between three different CPV technologies distributed accordingly to Figure 2-4. The shortest perimeter of the platform is about 384 meter, in the north-south direction. To each tracker, a DC/AC converter is connected. These converters are feeding 0.4 kV AC to one field-located transformer for every 1 MW aggregated peak output (Enercoutim, 2016b).

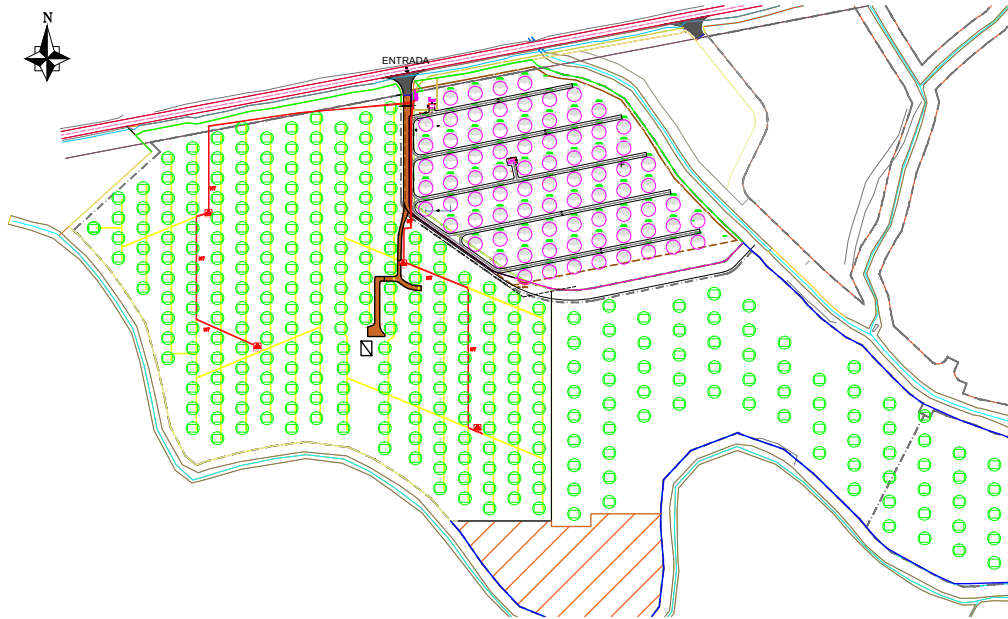

Figure 2-2. Sketch of the SDP with the installed trackers as green and purple circles. The 15 kV voltage level of the internal grid for one of the CPV technologies is shown as red lines (Enercoutim, 2016b).

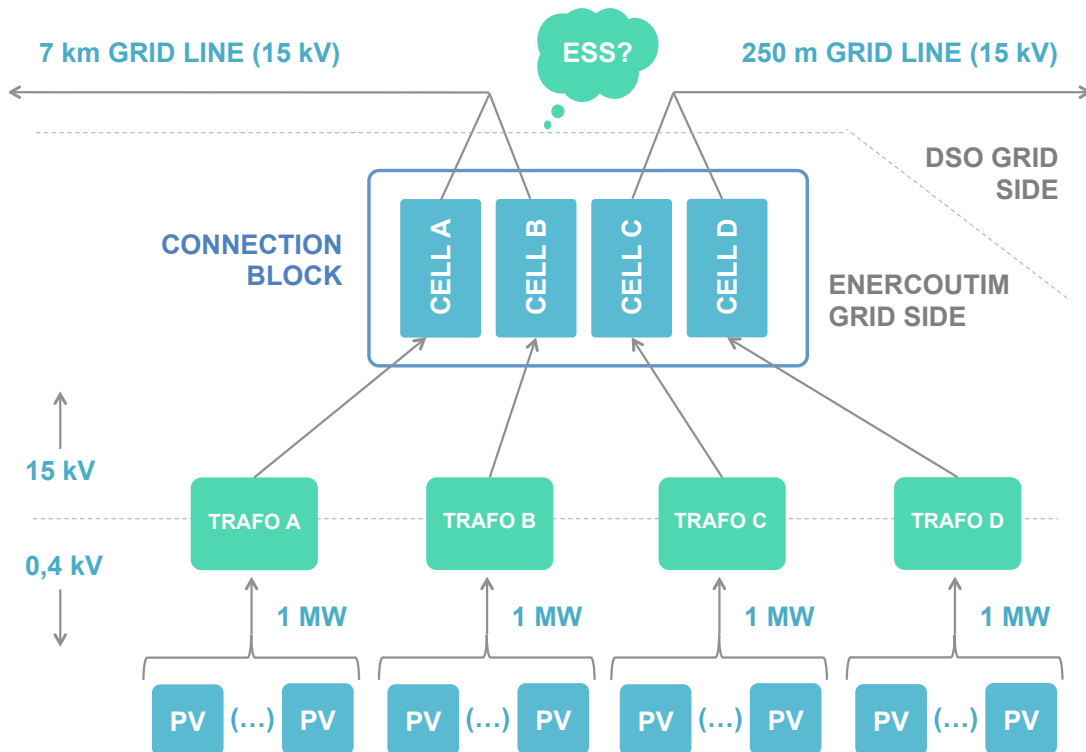

Figure 2-3. Sketch of the system layout, as of the time writing, from the power producing trackers at the bottom, to the DSO export connections on top. Also the suggested level of ESS-to-grid connection is marked out.

According to João Correia de Oliveira, project manager director at Enercoutim, there are plans to increase the SDP for the future in different stages. The first stage is to increase the installed capacity at the SDP to 6 MW and then continue with further installation of solar power in the future. The DSO has though concluded that an increase of 1.5 MW of power output to the current grid connection point could jeopardize the stability of the distribution grid. Instead there are plans to build another grid line to connect the additional 1.5 MW (and further installations) to a new connection point.



Figure 2-4. Picture of the SDP from air with the trackers visible (Enercoutim, 2016a).

2.3.2 Concentrator Photovoltaic (CPV)

The SDP is a project aimed to demonstrate new concepts for introduction, operation and management tied to novel solar power production technology. The technologies currently installed are three types of concentrator photovoltaic (CPV). This technology produces electricity immediately from the sun's direct irradiation, through a very efficient photovoltaic cell. Many cells, together with its solar concentrator, are arranged in modules, and a number of modules are placed on a sun-tracking device (tracker). A sketch of this arrangement can be seen in Figure 2-3. This sketch in particular shows a tracker holding 4 sets of 4x4 modules, but the number of modules per tracker can vary depending on the hardware producer.

The core principle of the cell is the same as in ordinary roof top PV panels. However, this cell has been engineered to convert the photonic energy into electricity with efficiencies up to 39 % (Philipps & Bett, 2016). This is more than twice the efficiency of a standard PV cell (Fraunhofer ISE, 2016).

Above the power producing cell sits a Fresnel focal lens, concentrating the incoming solar rays onto the cell. In this way the surface area of the costly cell can be kept small with a retained high area of absorbed light. However, since the lenses only focus the rays from one specific direction, the whole unit depends on always being oriented directly towards the sun. That is why multiple modules (each containing a grid PV cells and lenses) are arranged in a grid onto a tracker. The tracker follows the sun's exact path with a two-axis tracking system, according to a sun tracking algorithm and real time measuring (Philipps & Bett, 2016).

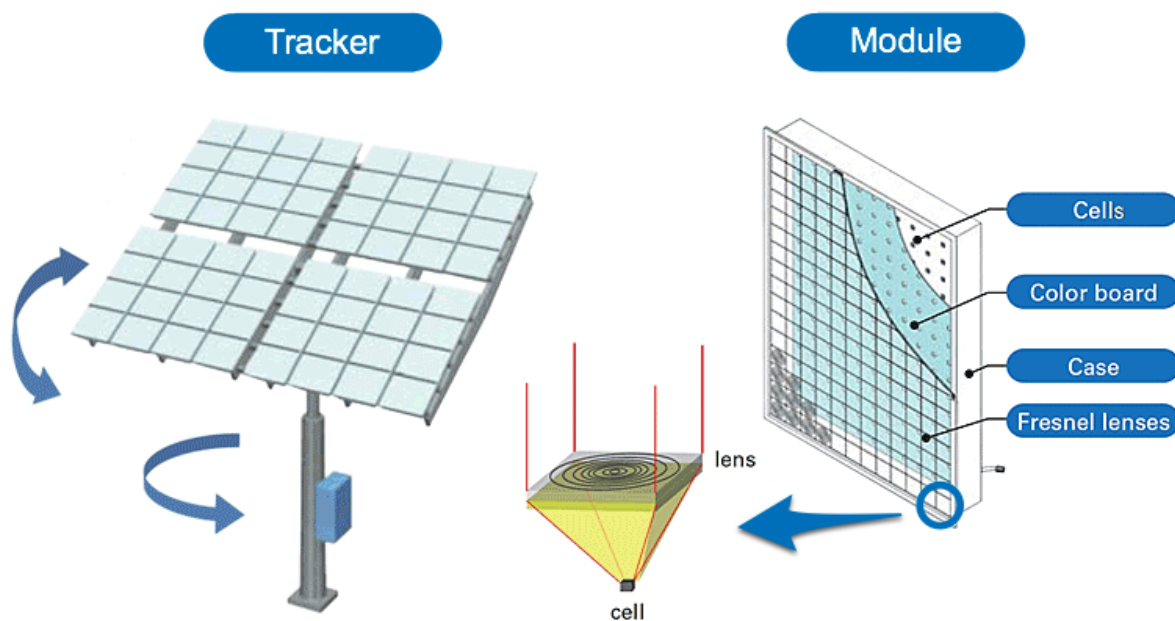

Figure 2-5. Sketch of CPV technology similar to the one used at the SDP (Sumitomo Electric Industries, Ltd., 2014). Picture edited by author.

2.3.2.1 Output Variability Due to Passing Clouds

Besides the seasonal and daily variations of solar-based power production, the largest and fastest output variations occur due to passing clouds. A number of studies have been conducted on the variability of commercial PV plant output. One example is the Springervilles 4.6 MW PV plant in Arizona, which was observed to have an extreme output change of 50 % of installed capacity per minute (Curtright & Apt, 2008). In the case of a 2.95 MW PV plant in Fontana, California, it was concluded that the largest of these events increased PV output by 2.20 MW or 75 % of installed capacity per minute (Norris & Dise, 2013). For two commercial PV plants in Spain, 90 % and 70 % output variation per minute was recorded. The plants were rated 1 MW and 10 MW respectively (Marcos J. , Stork el, Marroyo, Garcia, & Lorenzo, 2014).

Another study created by M. Sengupta in 2011 suggests that ramp ups to around 4 MW could be reached within 10 seconds in extreme cases (Sengupta, 2011). These results were not based on real PV plant outputs but on irradiance measurements (global horizontal irradiance) from 17 dispersed sensors on Hawaii. The measurements were then translated to PV output using the PVWatts model. The fact that the measurements originate from Hawaii makes the result less applicable to our case. Mainly this is because of the great difference in location, and therefore possible climatic differences. However, the results showing a possible 4 MW ramp over 10 seconds is a significant difference from other studies.

All the mentioned cases refer to plants with (non-concentrator) commercial PV technology. Since PV technology takes advantage of the global solar radiation, modules keep producing power even during periods of cloud coverage, but naturally at lower outputs. CPV modules on the other hand depend on direct irradiation, thus they do not output any power during cloud coverage. This is why the output fluctuations are expected to be even higher for CPV based power plants.

Fast variations in multi-megawatt power plants pose concern for grid operators, having to balance these events. This leads to that the concept of power output smoothing is already a hot issue for increasing grid stability related to large scale PV-installations (Marcos J. , Stork el, Marroyo, Garcia, & Lorenzo, 2014) (Haaren, R, 2014). In this sense, the word stability refers to avoiding big variations in voltages, currents and power. Furthermore, the importance of output smoothing measures is expected to be even higher for CPV installations, because of their higher power fluctuations.

3 Energy Storage and Service Overview

3.1 Regulatory Environment

The concept of energy storage is increasingly discussed in Europe today. With the five stated goals of the European Energy Union; supply security, fully integrated internal energy market, increased energy efficiency, emission reduction and research and innovations (European Commission, 2016a), ES can contribute to all of them. Thereby it will play an important role in the pursuit of these goals. Even though the advantages are many, ES are not widely used (other than some cases of PHS) in the European electric energy system. One of the major reasons is the unclear, or non-existing, common EU regulations. This is in particular true when talking about electricity-to-electricity (ETE) ES. According to the Policy department A – Economic and scientific policy, a department of the European parliament, *“technological developments need to be complemented with coherent policies and market design to fully unleash the potential of energy storage”* (European Parliament, 2015). Solutions for ES in the electricity market are relative new and today there is no coherent policy and market design within Europe. This causes problems for both the manufacture and the buyer of ES. The fact is that each country has its own regulations, or lack regulations. In addition, regulation that at this point often is in the developing process is consequently in the constant risk of being change in the near future (European Parliament, 2015). When the European Association of Energy Storage (EASE) made a survey 2012 over European countries’ regulation related to ES, Portugal was not mentioned. 12 countries had regulation or both regulations and standards in place, or they had defined segmentation between technology, application or location of ES. Some of these countries, especially Germany, had very specified and detailed regulation. Others countries had few and very general regulations, and often not specifically for ES. This reflects the complexity and diversity of the regulatory environment in Europe today (European Commission, 2015b).

Portugal is using the economical incentive of feed-in tariffs to increase the amount of installed RE and the CPV technology is included here. This means that a CPV power plant gets compensated for generation costs for a set amount of years, with an annually decline of the compensation. The feed-in tariffs have led to a great increase of installed RE in Portugal, but at a high cost considering national economy. Portugal has today the highest tariff debt in Europe because of increased subsidies, which is one of the reasons of the increased electricity price. With the goal to eliminate this debt until 2020, Portugal needs to implement plenty of effective regulations. One way to cope with the rising tariff debts is to negotiate down the feed-in tariff prices and also shorten the time period of the subsidies (IEA, 2016).

3.1.1 Regulatory Environment in the Future

As mention before, Portugal does not have any specific regulations directed towards ES, but they do have an increasing amount of RE production of wind and solar (25.7 % in 2013) (IEA, 2016). Many countries, including Portugal, are looking at how the regulations can be developed to further integrate the RE expansion. Here ES can play an important role. In this thesis, different countries’ approach towards future integration of RE is discussed, as well as the political guidelines stipulated by the

European parliament. This helps in trying to predict how the regulations could develop in the future, specifically for Portugal.

The European commission has declared that the European electrical energy system is in a period of fundamental change. It is of great importance that the organization and regulations of the market is carefully evaluated and potentially modified in order to function as efficiently as possible. One of the driving forces for this fundamental change is the on going gradual transition from mainly centralized power plants to decentralized power plants of RE production (European Commission, 2015c). With an increase of RE in the future grid, there will be the challenges of intermittency, where ES can play an important role. The European Commission announced in 2015 its *“Energy Unit Summer Package”* that will work on a new design for the energy market. The focus is on sorting out the position of ES in this market, and defining the services ES will provide in the future (European Parliament, 2015).

Another important issue is to clarify a common definition of what role ES has and will have in the electrical grid. Today different countries within the EU have different definitions, which is leading to that ES is participating in different markets. Depending on if ES is defined as a load, as generation unit or both, the grid fees are different. This is currently discussed in Germany and a proposal to solve this proclaims that ES, that exclusively feed back the stored energy to the grid at a later time, will be excluded from grid fees (European Parliament, 2015). Germany has implemented a market for primary, secondary and minute reserve, which further give ES access to new markets for its services. In Ireland the transmission system operator (TSO) also wants to create new markets by performing segmentation of ES, depending on services. This segmentation suggests that, for example, an ES that is providing transmission services should be treated as a transmission asset and not as a normal generation unit (European Commission, 2015b).

The variable power output from wind and solar power has also caused several countries to discuss and implement regulations of maximum ramp rate (power output variation during a defined time period) (California ISO, 2010). Scotland and EirGrid in Ireland has implemented a ramp rate limit for wind power and Alberta Electric System Operator has proposed to implement a 4 MW per minute ramp rate limit. In addition to these countries, both the TSO in Germany and in Puerto Rico has implemented a rate limit of 10 % of installed capacity per minute for wind and PV power production respectively (Exeter Associates Inc, 2007).

Today there is no clear answer to what share of intermittent energy an electric power system can cope with, before large-scale grid connected ES is needed in order to guarantee the stability of the system. Instead the problems with large amounts of intermittent energy production is location dependent in terms of grid design, local loads and the distance to other connection points. (European Parliament, 2015).

3.2 Technology

3.2.1 Overview of Energy Storage Technologies

Energy can be stored in various forms and with the help of a wide range of different technologies. The technologies used, and the way the energy is stored, determines what type of energy that can be regained from the storage. In the same way, parameters like round trip efficiency (RTE) and discharge rate is often closely related to the specific technology of choice. A common way to classify ES technologies is by the form of energy the storage charges up on. These categories are often defined as chemical, electrical, electro-chemical, thermal and mechanical. All of these storage types were summed up in 2014 and the total worldwide installed rated power capacity for large-scale energy storage was approximately 146 GW². This number includes e.g. heat storage but excludes small-scale energy storages like home battery systems (IEA, 2015a). To put the storage capacity into perspective, the total global installed electricity generating capacity was 2012 roughly 5 550 GW (IEA, 2012).

The scope of this thesis is to review ES types capable of ETE storage, but not thermal ES or electricity-to-gas storages. Figure 3-1 shows different ES technologies defined by EASE with added figures to illustrate which ES that are further reviewed and which are not.

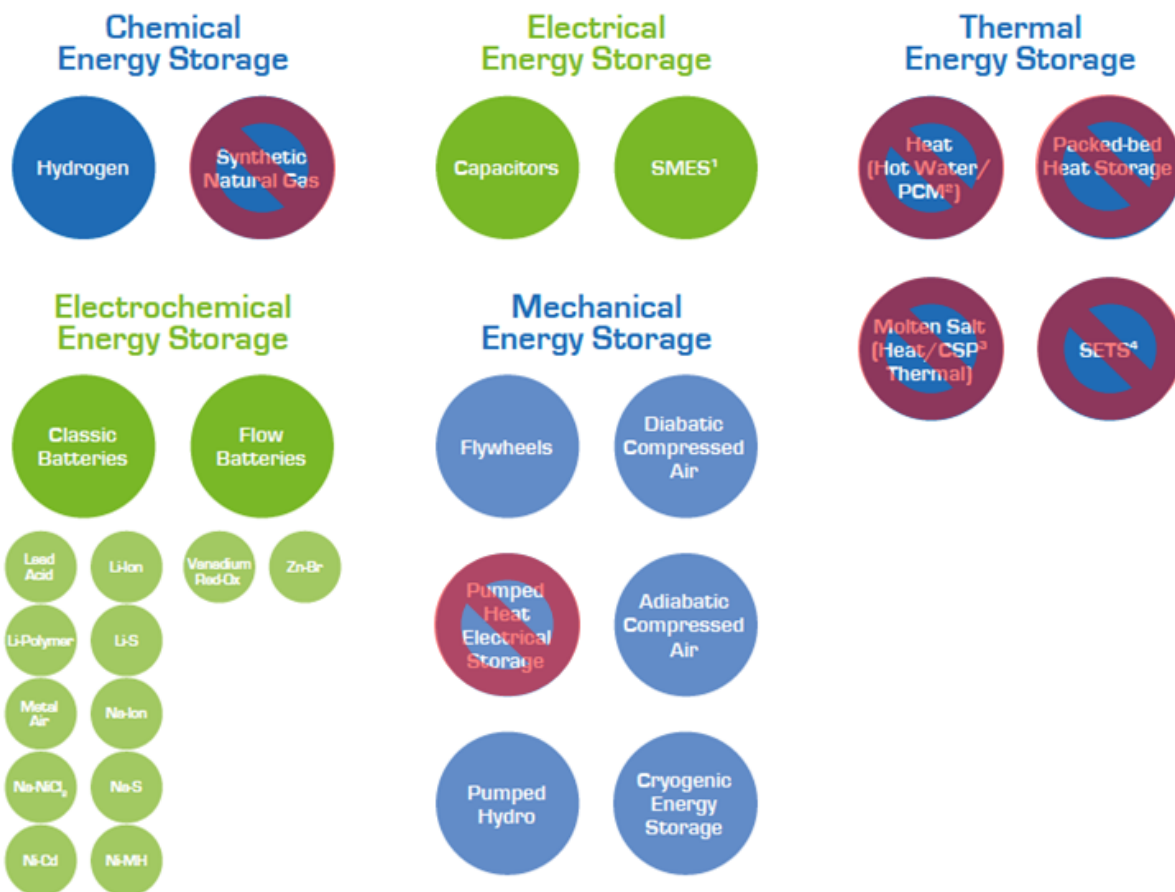

Figure 3-1. Overview of different types of ES according to their technology families (EASE, 2016a). Picture modified by author.

² Energy storage capacity can also be quantified in terms of energy, instead of power.

Pumped hydro is by far the biggest technology in terms of installed capacity. It is capable of providing about 140 GW, which is about 97 % of the total installed capacity (IEA, 2015a). This huge lead is most easily explained by the technologies maturity, which often leads to an advantage in price. ES in the form of pumped hydro are exclusively large-scale projects, compared to other ESS, which generally are smaller scale. This notion, together with a long asset lifetime and the fact that mostly conventional materials and technologies are used, leads to a particularly low cost per MWh (SBC Energy Institute, 2010a).

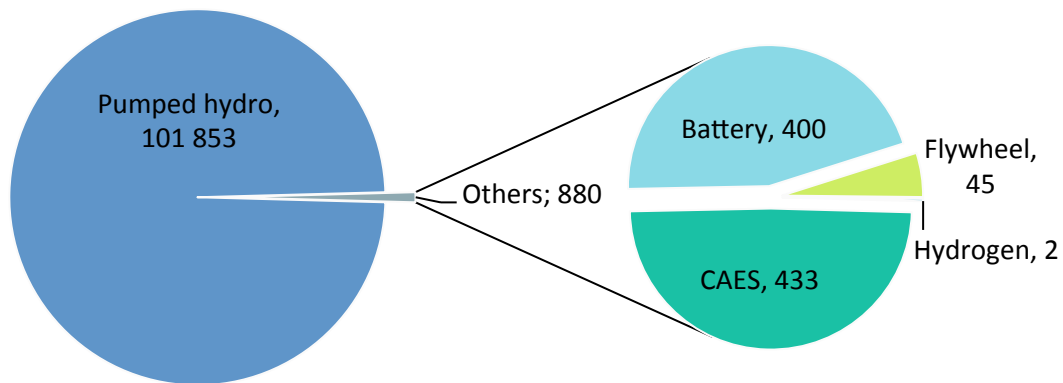

Figure 3-2. Total global rated power of operational grid-connected ETE ES technologies 2016. Numbers show MW (DOE, 2016a)

3.2.1.1 Pumped Hydro

In a pumped hydro power plant, water is pumped between two reservoirs that are located at different elevations. The facility takes advantage of the difference in gravitational potential at the two reservoir levels, through one or several reversible turbine installed in between them. The ES is being charged when the turbine is run as a pump to move water from a low to a higher state of potential energy. At times when energy is needed in the grid, water is released from the higher reservoir to run through the turbine, which now works as a generator. In this way the potential energy is converted back to electrical energy (ESA, 2016c). However, a limiting factor for this technology is the requirement of large submergible areas with specific topographical features. The RTE for pumped hydro energy storage lies usually around 75-85 % (Larsson & Ståhl, 2012).

3.2.1.2 Flywheels

Flywheels are, like pumped hydro, a type of mechanical energy storage. However, while pumped hydro power plants are able to store large energy quantities over long time periods (months), flywheels store considerably smaller amounts of energy over shorter time periods (seconds to hours). In a flywheel the energy is stored as rotational potential energy within a unit of spinning mass. During charge up, the mass is accelerated to high rotational speeds with a motor and kept spinning with low frictional losses –

preferably in vacuum. When the stored energy is needed, the same motor acts as a generator and magnetically slows the rotation. In this way high power levels can quickly be dispatch to the grid over short time periods. In modern flywheels the spinning mass is held in place by magnetic bearings instead of conventional ones. This leads to lower friction losses and higher rotational speeds, which increases the overall efficiency of the energy storage (ESA, 2016d). The RTE is around 85-90 % (Larsson & Ståhl, 2012).

3.2.1.3 CAES

Compressed air energy storage, often abbreviated to CAES, is a third way of storing energy mechanically. The globally installed production capacity of the technology is approximately 1.6 GW (DOE, 2016b). The principle of CAES is to use excess energy to compress big volumes of air, and in this way to charge up on mechanical energy, similar to a compressed spring. When the energy is needed, the compressed air is expanded through a turbine, either with or without the simultaneous burning of natural gas. Through this turbine the energy is converted back to electrical energy. The heat that is extracted in the process of compression is either cooled away from the system (diabatic) or it could be stored and used for the air expanding process (adiabatic) to increase RTE. For utility-scale CAES, the compressed air is most often stored within pre-existing cavities within the ground. The most suitable storage alternatives are usually salt caverns. However, also aquifers and depleted natural gas fields are being investigated as alternatives (ESA, 2016e). For conventional CAES technologies, the need for specific geological condition implies real limitations for new establishments, as the case for pumped hydro. However, new companies are working on overcoming this problem by developing aboveground isothermal CAES systems (LightSail Energy, 2016) (SustainX, 2016). Usually the RTE of this technology is 50-70 % (Larsson & Ståhl, 2012).

3.2.1.4 Hydrogen

Hydrogen ES belongs to the category of chemical energy storage. The fundamental process of this technology is to chemically change an initial substance to end up with a different one. This means, chemical structures are getting altered, as opposed to (only) the ionic charges being moved and exchanged in electro-chemical energy storage. When the hydrogen ES is being charged, electrical current is fed into an electrolyser, where water molecules are separated into their constituents hydrogen gas and oxygen. The hydrogen gas is collected and stored either in underground caverns, or above ground pressurized containers. The gas can also be cooled to a liquid state in order to minimize required storage volume. When additional power is demanded on the grid, the hydrogen can either be fed through a hydrogen fuel cell or be combusted in a gas turbine, to re-generate the electrical power. Hydrogen has the possibility to provide long time storage but one of the main problems today is the low RTE, between 30 and 50 %, and high costs (ESA, 2016f).

3.2.1.5 Batteries

Battery energy storage systems (BESS) all depend on an electro-chemical process in order to store energy over time. In this report the term batteries include both the group of solid state batteries and the ones called flow batteries. The separation between the two types, refer to the solid or liquid state of the unit storing the electrical charge. In both cases, electric potential is built up or released as electrons move via an external circuit, between the positive and negative electrode of the cell. Ions move in the opposite direction via an electrolyte, to balance the charges. In solid state batteries, it is the solid

electrodes holding the electrical charges. In flow batteries, on the other hand, it is the liquid electrolytes that are charged. In this process, the electric potential is achieved as the two liquids are pumped from their respective tanks to chemically react over a membrane, allowing ions to be exchanged. The amount of energy that a flow battery is able to store is solely determined by the amount of electrolyte used, and its energy density. Since the electrolytes are generally stored in tanks, outside the flow cell, these can rather easily be changed in size (ESA, 2016g) (Buchmann, 2016) (Service, 2015). The RTE of most batteries is between 60 and 95 % (Larsson & Ståhl, 2012).

The most common solid state battery types used today for grid-connected applications are Lithium-ion (Li-ion), Sodium-sulphur (NaS) and Lead-acid batteries. On the flow battery side the most used technology is the one based on Vanadium Redox (VRB). However, the Li-ion battery is today, the most widely used battery technology for grid applications (DOE, 2016c).

3.2.1.6 Capacitors

A capacitor, also sometimes referred to as super capacitor, ultra-capacitors or electric double-layer capacitor is another technology to store energy electro-chemically. Although, sometimes it is instead categorized as a strictly electrical energy storage device, to more distinctively separate it from the battery technology. The characteristic of the capacitors storage method is the use of high-surface-area carbon electrodes, between which an electrical charge is generated and maintained for the purpose of storage. The electrodes are usually made from activated carbon, and between the layers an electrolyte is present. With this architecture, charges are stores physically without any changes in chemical composition. This attribute gives the technology a very fast response time (millisecond level), a very high charge-discharge cycle limit (order of million), combined with a high RTE (85-98 %) (Larsson & Ståhl, 2012). The drawback is that the amount of stored energy is very limited. Therefore the main field of grid-connected applications lay in fast acting, high-power and short-duration uninterruptible power supply (UPS). To date, the installed storage capacity for grid-connected capacitors is very limited (ESA, 2016g) (EASE, 2016b).

3.2.1.7 SMES

Superconducting magnetic energy storage (SMES) is a technology belonging to the family of electrical energy storage. This device's core component is a superconducting coil. When current flows through this coil a magnetic field is generated, and it is in this magnetic field that a certain amount of energy can be stored. To maintain the superconducting characteristics of the SMES device, the coil has to be kept at very low temperatures. Since the charge-discharge time only depends on the rate of current flowing through the coil, these devices have extremely fast response times. The application area of this technology is similar to the one for capacitors and focus on high-power and short-duration power quality control (SBC Energy Institute, 2010b). Like in case for capacitors, the RTE for this technology is high, around 95 % (Larsson & Ståhl, 2012).

3.2.2 Early Discarded ES Technologies

The maturity of the type of ES acts often as an important indicator of the risk level connected with committing to a certain technology. With greater maturity comes usually more knowledge regarding asset lifetime, optimal operation condition and operation and maintenance costs, among others. In

Figure 3-3 the maturity levels are represented for various ES technologies, as described by Decourt & Debarre, as a function of the capital investment times the technology risk (Decourt & Debarre, 2013a). Other representation of this maturity curve can be found in a report by Palizban & Kauhaniemi in 2015. This report also includes the Lead-acid battery, which comes in at a higher maturity level than the Lithium based technology (Palizban & Kauhaniemi, 2016a).

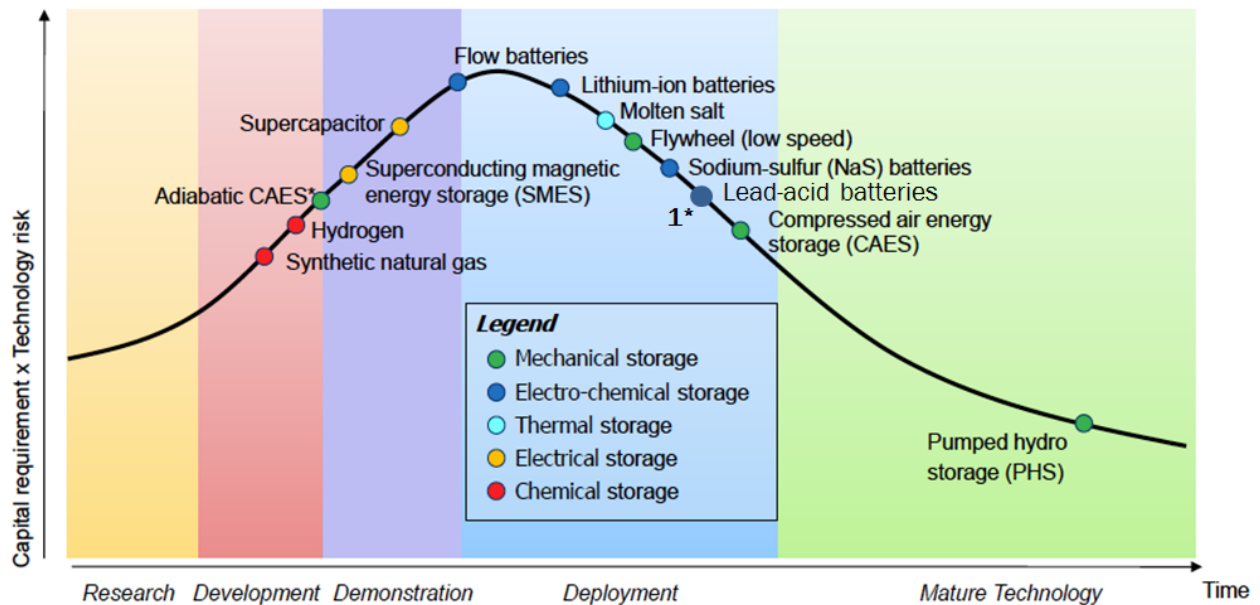

Figure 3-3. Technology Maturity Curve for different ES technologies (Decourt & Debarre, 2013a)

1*: Lead-acid is not included in the original figure and instead added according to other sources (Zakeri & Syri, 2014) (IEC, 2012).

In the search for the most suitable energy storage technology for the SDP in Martim Longo, some technologies can be discarded early on. This elimination is necessary for being able to make a deeper analysis of fewer but more relevant technologies further on. As described in the prior topic, some ES technologies are too site-dependent, as they require special features of the area it will be deployed in. Pumped hydro can at this point be discarded from the range of possible ES types. The reason is the need for a special topographical profile, which is not present in the Martim Longo area, and especially not within the borders of the platform, see chapter 2.

CAES is the second technology that inevitably falls into the same category as pumped hydro. As described in chapter 2, there are no recorded depleted mines or caverns of any kind in the proximity of the site. Furthermore, aboveground compressed air (which is not site specific) is at this point not regarded as a mature technology.

Hydrogen ES is a promising technique for longer-term storage of energy. However, at this point hydrogen is still regarded as an immature technology, see Figure 3-3. This is reflected by the limited number of hydrogen energy storage systems that are up and running today (DOE, 2016a). Moreover, only one of the running projects is able to convert the produced hydrogen back to electrical energy on site. As

mention before, only an ETE solution is of practical use, and thus sought after. This leaves the conclusion that hydrogen ES will be disregarded in the future analysis of this report.

Other technologies that generally are considered immature for grid-connected ES are capacitors (supercapacitors) and SMES. In addition to being fairly new on the market, the investment costs for these devices are high, especially in costs per unit of energy (Decourt & Debarre, Electricity Storage Factbook, 2013b). Because the general approach of this master thesis treats the implementation of ESS for balancing a bigger share of renewables, the scope is wider than providing high-power, short-duration power supply, like the case for UPS. These are all reasons why capacitors and SMES are disregarded as possible ES technologies for the SDP. This is also the reason why flywheels are discarded. Flywheels can actually store energy up to some hours but the energy losses are much greater over these time scales. This makes an ESS of this type more limited in question of possible provided services.

Flow batteries are sometimes considered to be in the deployment zone but more common in the demonstration zone. According to Figure 3-3, flow batteries are considered as a technology in the demonstration zone, towards the deployment zone, and will thereby be discarded. This is also supported by the fact that only 0.6 % of the grid connected operational batteries today (in terms of installed MW) are flow batteries (DOE, 2016c).

There are plenty of new types of batteries that are developed today, some still in the laboratory and some that are newly deployed. Most of these batteries are new additions to the same kind of battery families, but with a different combination of elements. In this thesis all different kinds of lithium, lead and sodium batteries will be included in the Li-ion, Lead-acid and NaS family for simplification reasons, and for the reason to maintain the scope. Therefore any specific individual technology paths, under one of the three mentioned battery families, are crossed out in Figure 3-4. This only indicates that we are not going to assess these specific technology subcategories.

What follows below is a section for summarizing the so far discarded ES technology types, not suitable for application at the SDP:

Discarded technologies mainly due to unfulfilled site requirements:

- Pumped hydro
- Compressed air (CAES)

Discarded technologies mainly due to immaturity:

- Hydrogen
- Capacitors
- SMES
- Flow batteries

Discarded technologies mainly due to limiting factor concerning possible provided services:

- Capacitors

- SMES
- Flywheel

Discarded technologies due to immaturity and/or included in the Li-ion, Lead-acid or NaS family:

- Li-Polymer
- Li-S
- Metal Air
- Na-Ion
- Na-NiCl₂
- Ni-Cd
- Ni-MH

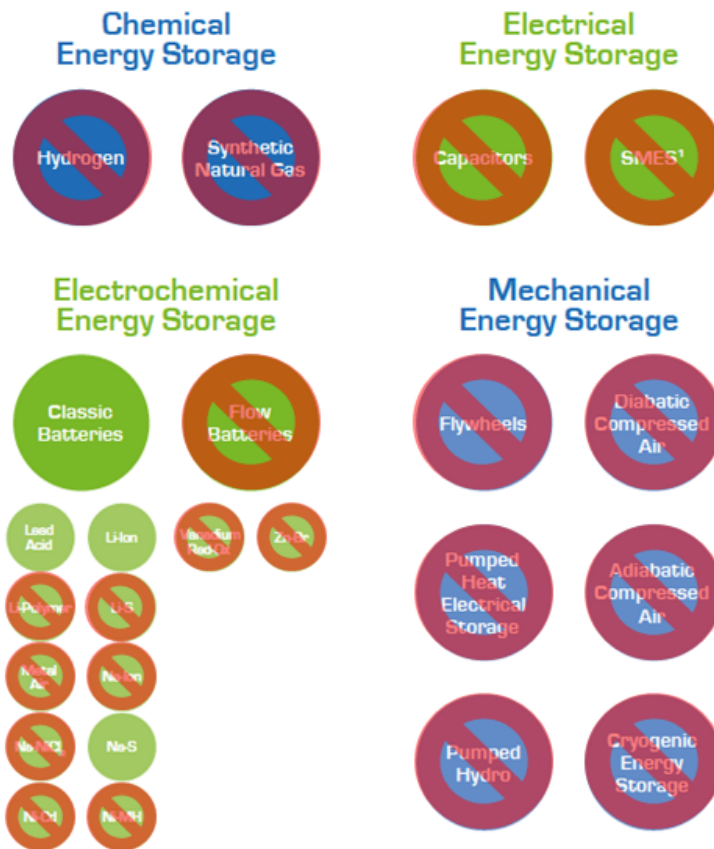

Figure 3-4. Illustration of discarded and the remaining ES technologies for this thesis at this stage.

3.2.3 Review of Possible ES Technologies for the SDP

The remaining, Li-ion, Lead-acid and NaS batteries, are mentioned to be the most suitable ES technologies for the SDP when consider the fact and reasoning presented in chapter 3.2. To understand how these three technologies perform and what special characteristics that describe them, a deeper and more detailed explanation is provided in this subchapter.

The market for grid-connected large-scale battery ES is dominated by Li-ion, NaS and Lead-acid batteries (in the mentioned order). They together account for about 88 % of this market, which is a further indication that these three BESS technologies are the most mature and tested in this area. The relation of all installed and operational battery storage solutions is shown in Figure 3-5.

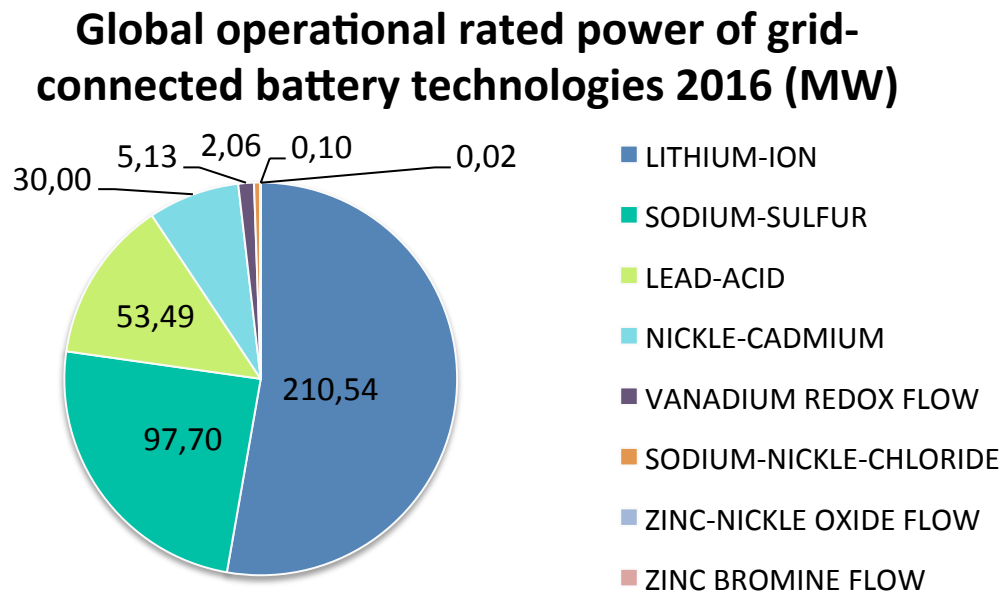

Figure 3-5. Overview of global installed and operational power output of battery technologies 2016 (DOE, 2016c).

In the following section, battery technologies will be discussed in terms of their respective battery families, e.g. Lithium battery family. Each battery family possibly holds several technologies with the same main reactive component, e.g. Li-ion Titanate and Li-ion Phosphate, both within the family of Lithium batteries. The same reasoning is applied for Lead-acid and NaS batteries.

3.2.3.1 Lead-acid Batteries

In this assessment, the family of Lead-acid batteries holds both the traditional and more advanced versions of the Lead-acid technology. The traditional Lead-acid battery is mostly known for its extensive use for conventional combustion engine cars. However, Lead-acid battery packs have for a long time been the standard solution for providing stationary backup power for high availability applications, like hospitals and communication infrastructure (Linden & Reddy, 2002) (Battery Council International, 2016). Thanks to research and development initiatives, a branch of this technology has been refined to the point it is called an advanced Lead-acid battery. Because the fundamental principle of the Lead-acid

battery is very much mature, the whole Lead-acid battery family is considered to be a mature technology throughout this report.

One evolution of the Lead-acid batteries is based on the use of carbon as an enhancement of the negative electrode. This technological advance makes the Lead-acid battery more versatile within the field of different ES applications. While conventional Lead-acid batteries in back-up power applications are typically held at full charge between discharge events, the ability for partial charge operation is essential for applications like PV output smoothing. In addition to the possibility to operate for extended periods at a partial charge, advanced Lead-acid batteries can also reach high rates of charge and discharge. One advanced Lead-acid battery system developed by Ecoult and East Penn Manufacturing Co., Inc. is the so-called UltraBattery. This battery is particularly efficient in providing fast response to for grid stabilizing applications. It possesses the capability of frequency regulation (described in chapter 3.3) on the MW scale, acting according to the American PJM electricity market’s frequency regulation signal. Typical power regulation results in 10 % - 30 % State of Charge (SoC) range (McKeon, Furukawa, & Fenstermacher, 2014). Another Lead-acid battery solution provided by Xtreme Power is able to deliver frequency regulating power instantly within a 50 milliseconds of response time (IRENA, 2015).

Finally, as (McKeon, Furukawa, & Fenstermacher, 2014). conclude in their article, the Lead-acid battery technology is today able to provide power handling performance combined with long lifetime, competitive with other battery chemistries. What is also pointed out is the advantage of the technology being well known by industry and within transport, supported by existing fire and safety standards, and the Lead-acid battery’s high recyclability.

Table 3-1. Characteristics for Lead-acid batteries for different applications (IRENA, 2013) (IEC, 2012). For “Cycles life depending on SoC” (Subburaj, Pushpakaran, Bayne, 2015).

BESS	Power rating [MW]	Energy rating [MWh]	Discharge time	Response time	Cycles life for 20% SoC	RTE	Expected life time
Lead-acid	0.01-10	0.1-1	Seconds to Hours	< 1 sec	200-300	75-90	3-15

3.2.3.2 Li-ion Batteries

The Lithium battery family houses a number of technologies where the anode material consists of intercalated Lithium (modified with other molecule or ion) and the electrolyte is a liquid polymer (Kurzweil, 2015). In general, Li-ion batteries are able to accept high charge rates and also deliver high rates of discharge. Furthermore, the technology offers low self-discharge rates, around 5 % per month, and has one of the highest RTE of all batteries (Palizban & Kauhaniemi, 2016c). On the downside, it has to be mentioned that their performance decreases with high temperatures, which results in a need for a thermal control system, which partly explain the higher operation and maintenance cost. Li-ion batteries also handle SoC at 0 % without a significant decrease of expected lifetime (Zakeri & Syri, 2014).

Table 3-2. Characteristics for Li-ion batteries for different applications (IRENA, 2013) (IEC, 2012). For “Cycles life depending on SoC” (Subburaj, Pushpakaran, Bayne, 2015).

BESS	Power rating [MW]	Energy rating [MWh]	Discharge time	Response time	Cycles life for 0% SoC	RTE	Expected life time
Li-ion	0.01-10	0.1-10	Seconds to Hours	< 1 sec	3000	85-98	5-15

3.2.3.3 NaS Batteries

Batteries belonging to the Sodium family uses sodium (Na) as the negative electrode and sulphur (S) as the positive electrode. This family holds mainly two different designs, called Sodium-sulphur and Sodium-Metal-Halide. In this report focus will be kept on the Sodium-sulphur variant, primarily because its greater share of installed capacity and consequently greater operation experience (Moseley & Rand, 2015). The NaS battery requires a working temperature of around 350 °C in order to keep the negative electrode (the sodium) as a liquid. Consequently, this requires a sophisticated thermal regulation and safety system (Palizban & Kauhaniemi, 2016c). Even though NaS batteries work in higher temperature than other batteries it keeps the operational costs relatively low. The advantage is relative high energy efficiency, long expected lifetime along with the ability of very flexible operation (Zakeri & Syri, 2014).

Table 3-3. Characteristics for NaS batteries for different applications (IRENA, 2013) (IEC, 2012). For “Cycles life depending on SoC” (Subburaj, Pushpakaran, Bayne, 2015).

BESS	Power rating [MW]	Energy rating [MWh]	Discharge time	Response time	Cycles life for 10% SoC	RTE	Expected life time
NaS	0.03-10	0.1-100	Seconds to Hours	< 1 sec	2500	70-85	10-15

3.3 Services

3.3.1 Overview of Services Provided by Energy Storage

The electrical grid is in the middle of a transformation period where the traditional way of supplying electricity, where several huge generation units deliver electricity to the customer, is challenged by an increase of RE delivered to the grid. The system is slowly changing from having several centralized big generation units, which produce electricity exactly when it is needed, towards more RE generation units. These units are generally smaller and distributed over a variety of places, with the disadvantage of only producing electricity when the conditions are right. This change in the electricity production generate new challenger for the grid. Everything from maintaining the right voltage and frequency on the grid, to building new distribution and transmission are possible measures in order to manage this system change. These efforts have to be considered to maintain a reliable electricity delivery (IRENA, 2013).

ESSs can provide a wide range of services to the producer, the grid operator and to the customer but there is a wide range of different definition and names of these services depending on which report that is reviewed. In order to present a reliable definition and categorization of services provided by ESSs, this report will use the definition given by (Akhil, et al., 2015), which is a complete report on the topic of energy storage from Sandia National Laboratories. In their report they have compared and combined the definition of several other reports and studies, and derived 18 services divided into 5 umbrella groups, see Figure 3-6 (Akhil, et al., 2015, pp. 35-36). By using one main source for service definition, instead of including several different ones, the risk of mixing service descriptions is minimized.

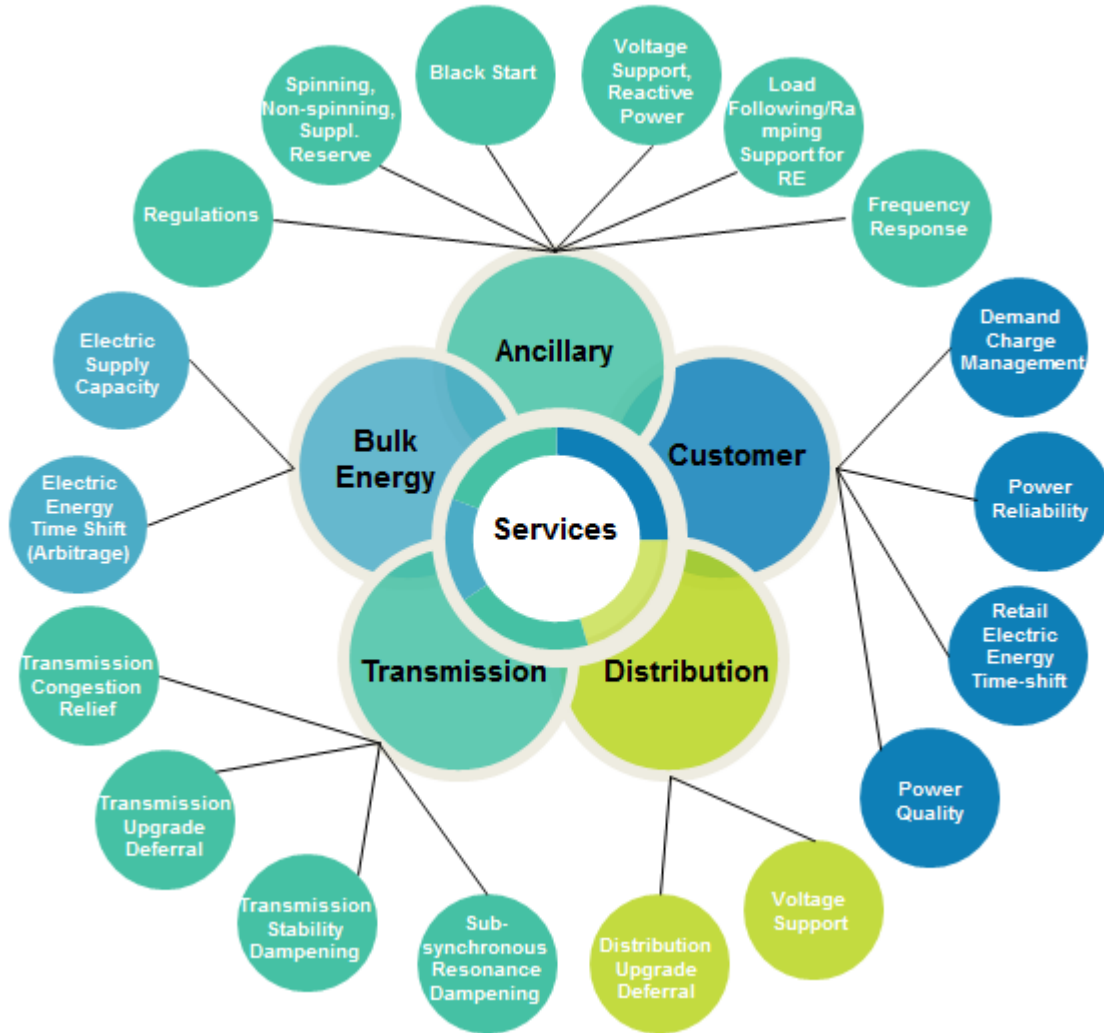

Figure 3-6. Illustrations of the five umbrella groups of services with related services that are considered for this thesis.

3.3.1.1 Bulk Energy Services

Electric Energy Time-Shift (Arbitrage)

Electric energy time-shift, or arbitrage, is the service when electricity is bought and stored when the price is low and later sold when the electricity price is higher. Another application is that energy is stored when in excess and released when the demand is higher.

The RTE is important when consider an investment in an ESS that can provide this service. If the RTE is too low, the money that the service can generate could be consumed by the energy losses (Akhil, et al., 2015, pp. 36-37).

Electric Supply Capacity

If the load exceeds the production at a certain location, different ESS can provide the electrical supply capacity service to the grid. The ESS then responds to the peak load and start to generate electricity to meet up the extra need, to prevent failure in the grid (Akhil, et al., 2015, pp. 37-38)

An ESS connected to the grid able to provide this service can postpone investments in new generation units. Today, these common generation units often rely on fossil fuel and their efficiency is often lower than the RTE of most ESS. Depending on the duration of the load peaks, the energy capacity and the response time of the ESS has to be considered (ESA, 2016a).

3.3.1.2 Ancillary Services

Regulation (Frequency and Fast Power Demand/Peak Shaving)

The grid always has to keep a balance between load and production to maintain the right frequency. Regulation of the frequency is generally maintained by generating units that can increase or decrease its production of electricity depending on the load. ESSs on the other hand add the possibility to not only increase and decrease its generated power but also to absorb energy from the grid when there is an overproduction of electricity. Because of this reason, ESS is well suited to provide this ancillary service to the grid. The fact that ESSs e.g. batteries and flywheels also have a faster respond time than conventional generating units increase the value of regulation even more (Akhil, et al., 2015, pp. 38-40).

Spinning, Non-spinning and Supplemental Reserves

Spinning, non-spinning and supplemental reserves is the generation that will kick in if a major generation unit suddenly become unavailable.

The spinning reserve is the first reserve to kick in and it is an always-present generation capacity that is unloaded but online. This type of reserve responds within 10 minutes, while spinning reserve for frequency regulation can respond within seconds. The non-spinning reserve is the second reserve to kick in in case of generation losses. The respond time is also within a 10 minutes span, but it is offline during periods when it's not needed for power generation. The supplement reserve is the last reserve to be used after both the spinning and non-spinning reserves are online. The responds time is within an hour.

An ESS that is used as a reserve needs to be operational and ready all the time and preferably also provide a high power output to be considered as a valuable reserve to the grid (Akhil, et al., 2015, pp. 41-43).

Voltage Support, Reactive Power

To maintain the necessary voltage level in the electric grid, operator needs to provide reactive power (VAR) to manage the reactance. The reactive power is today mainly provided by conventional generation units but because of inefficient transmission of reactive power over longer distances, the most efficient way would be to provide the reactive power close to the consumers instead. Distributed ESS (DESS) closer to the consumer has the possibility to provide this service to the grid without long transfer distances (ESA, 2016a).

Black Start

When a grid wide outage occurs there needs to be generation units to provide the service of black start to re-energize the transmission and distribution lines as well as to start up generation units that do not have the capacity to start without electricity available. Most ESSs can already provide the ancillary

service of black start without any extra equipment and can thereby replace generation units that generally provide this service today (Akhil, et al., 2015, pp. 44-45) (ESA, 2016a).

Load Following/Ramping Support for Renewables

Intermittent power generation like CPV, highly fluctuate in its energy output. With an increase of electricity produced by wind and solar generation units in the grid, the fluctuation needs to be compensated for. To compensate this variable output today, conventional generation units that rely on fossil fuel, need to be ready to kick in to stabilise the grid. A problem is that these kinds of generation units work best at a constant power generation. With a constantly changing power output, the efficiency of the generation unit will decrease. This in turn, will increase the amount of fuel per produced MWh, increase the emissions of carbon dioxide and decrease the unit's lifetime.

An ESS that can provide the ramping support service works in the same way as when balancing for fast load variations. The ESS is ramping up and down with the required power per time unit, e.g. MW/minute or MW/s, to both follow the fluctuation in load and in generation output. Compare to fossil fuelled generation units, the efficiency of an appropriate ES technology is almost the same when operating in a variable output condition as if the output would be constant.

A distributed ES that can provide this specific ancillary service also has good synergies with other services such as voltage support, electric energy time-shift and electric supply capacity (Akhil, et al., 2015, pp. 45-47).

The ancillary service Ramping Support for Renewables has many names. Depending on the literature it can be referred to as ramp-rate support, ramp-rate control, ramp-rate smoothing and ramp-rate limiting service (Haaren, 2014a) (Hill & Chen, 2012).

Frequency Response

The European grid needs constantly to be at, or close to, a frequency of 50 Hz. When a bigger generation unit or a transmission line fails to deliver electricity to the grid, the frequency will drop which could lead to an even bigger failure. To prevent these events from happening, the primary, secondary the tertiary frequency control units kicks in. The primary frequency control kicks in after a few seconds and stabilizes the grid, and to keep it from drifting further away from the setpoint. The secondary frequency control kicks in after around 30 seconds and takes over after the primary control. After 5 to 10 minutes the tertiary frequency control kicks in and brings the frequency of the grid back to 50 Hz. The frequency response works in the same way as the regulation service but with a shorter response time.

Depending on if primary, secondary or tertiary frequency control is needed, different ES can provide these services, generally twice as affective as conventional fossil fuelled units. The efficiency of the frequency response is highly dependent on where in the grid the ES is placed, with respect to other generation units, loads and transmission corridors (Akhil, et al., 2015, pp. 48-49).

3.3.1.3 Transmission Services

Transmission Upgrade Deferral

The transmission grid is built to have an over capacity to be able to deliver electricity even when the peak loads occurs. Over the course of a year, there are usually a few times when extreme peak loads occur. These peaks could result in an overuse of the transmission grid, which in turns will lower the lifetime of the equipment. This is generally the problem for older transmission lines, which were designed for a certain load but as the society continue to grow, the load will increase and the maximum capacity could be reached.

An ESS can delay an investment in new transmission lines, transformers and other electrical equipment by be used as a stand-by generation unit and deliver electricity just when the extreme peak loads occur. This results in the fact that the transmission grid is not used over its maximum capacity. The criteria for an ES to deliver this service is to deliver a high power output, between 10 to 100 MW, for 2 to 8 hours, while the cycles per year are generally only between 10 to 50 (Akhil, et al., 2015, pp. 50-51).

Transmission Congestion Relief

The problem with peak loads for the transmission grid can also occur at a single transmission line that could work as a bottleneck in the system. An ESS that could provide this service should be placed downstream of the congested point and deliver electricity when the maximum capacity of the single line is reached. The criteria for the ESS to deliver this service are similar as to the ESS for the transmission upgrade deferral. However, the power requirements could be lower, while the discharge time is half of the time one for the deferral service. The cycles per year are 50 to 100 (Akhil, et al., 2015, pp. 51-52).

Transmission Stability Damping and Sub-Synchronous Resonance Damping

To handle disturbances at the transmission grid, for example resonance, voltage dips or unstable voltage, an ESS could work as a stabilizer. In order to provide these services the ESS need to be able to respond within a second and deliver a high power output at once, but for a short period, which result in a low energy content. In addition the ESS needs to provide both active and reactive power to the grid and also handle many cycles per year (Akhil, et al., 2015, pp. 52-53).

3.3.1.4 Distribution Services

Distribution Upgrade Deferral

When bigger additional energy production or a load is connected to the distribution grid, there might be need for investment in new and more powerful electrical components. These could be bigger transformers and substations to keep the stress level on an acceptable level. To prevent similar investments in the close future, the dimensions of the electrical components are generally over dimensioned compared to today's real needs. This leads to a high, immediate investment cost with many uncertainties.

By implementing an ESS with the capability of deferring grid upgrades, the investment in new expensive electrical components could be postponed, at the same time as ideally other valuable grid services could be provided (Akhil, et al., 2015, p. 53).

Voltage Support

Voltage support is one valuable service that a DESS can provide. When a big intermittent generation unit is connected to the distribution grid, the voltage could start to fluctuate. To keep the voltage at a reasonable level in the distribution grid, the fluctuation can be dampened by an ESS, again lowering the stress level on the equipment (Akhil, et al., 2015, p. 54).

3.3.1.5 Customer Services

Power Quality

Customers downstream in the electrical system could, because of disturbances in the grid upstream, have problem with the quality of the electricity. Examples are variation in voltage, variation in the frequency, low power factor or periods without any electricity delivered, in the order of a few seconds. To increase the power quality, an ESS could work as a back-up unit to the grid. Depending on the customer, the design criteria for the ES is different, but power output is generally varying between 0.1 to 10 MW, discharge time between a few seconds to a few minutes, and a minimum cycle range between 10 to 200 cycles per year (Akhil, et al., 2015, pp. 55-56).

Power Reliability

If a customer is completely disconnected from the electrical grid for a longer time period, e.g. when a transformer at a distribution line stops to working, an ESS has the possibility to provide the service of power reliability. In order to deliver the service, the ESS needs to be able to work as the only generation unit in the local grid, and be able to resynchronize to the main grid when the power comes back. The energy content and the power output of the ESS is completely determined by the size of the load and how long the ESS should be able to provide electricity to the grid (Akhil, et al., 2015, pp. 56-57).

Retail Electric Energy Time-Shift

The main purpose with this specific service is to reduce the cost of electricity for the customer, expressed for example as EUR/ kWh.

Retail electric energy time-shift works in the same way as the bulk service, electric energy time-shift (arbitrage), but is only based on the cost of electricity for the customer - not the current wholesale price. The power output is not the limiting factor for an ESS providing this service, instead the energy content is the determining one. The more energy that can be stored, the more electricity could be bought at low price. It is important to calculate with the RTE in order to get the right value of this service (Akhil, et al., 2015, pp. 57-58).

Demand Charge Management

Demand charge management is a service to reduce the cost of electricity. This is done by lowering the demand when the load on the grid is high, and charging when the load is low. Instead of counting in EUR/kWh, as in retail electric energy time-shift, the value is expressed in EUR/kW. The demand prices are generally set by the grid utility and could vary between different time periods.

The power output from the ES depends on the customer, but the minimum limit should exceed the peak load of the customer. The energy content of the ES is mainly determined by the rated power of the ES

and for how long time the demand prices are higher than normal. As for retail electric energy time-shift, it is important to calculate with the RTE in order to get the right value of this service (Akhil, et al., 2015, pp. 58-59).

3.3.2 Summary of Requirements for the Different Services

Table 3-4. Summary of the different services in terms of system size, discharge duration and minimum cycles per year (Akhil, et al., 2015).

Type of service	Service	System size [MW]	Discharge duration	Min. cycles/ year
Bulk Energy Services	Electric Energy Time-Shift (Arbitrage)	1-500	< 1 hour	250
	Electric Supply Capacity	1-500	2-6 hours	5-100
Ancillary Services	Regulation	10-40	15-60 min	250-10 000
	Spinning, Non-Spinning, and Supplemental Reserves	10-100	15 min-1 hour	20-50
	Voltage Support	1-10 MVAR	-	-
	Black Start	5-50	15 min – 1 hour	10-20
	Load Following/Ramping Support for Renewables	1-100	15 min – 1 hour	-
	Frequency Response	20+	1 – 15 min	7 000- 15 000
Transmission Services	Transmission Upgrade Deferral	10-100	2-8 hours	10-50
	Transmission Congestion Relief	1-100	1-4 hours	50-100
	Transmission Stability Damping, Sub-synchronous Resonance Damping	10-100	5 sec – 2 hours	20-100
Distribution Services	Distribution Upgrade Deferral Voltage Support	0.5-10	1-4 hours	50-100
Customer Services	Power Quality	0.1-10	10 sec – 15 min	10-200
	Power Reliability	-	-	-
	Retail Energy Time-Shift	0.001-1	1-6 hours	50-250
	Demand Charge Management	0.05-10	1-4 hours	50-500

3.3.3 Discarded Services

In chapter 3.2.3 *Review of Possible ES Technologies for the SDP*, the conclusion is that the possible ES technologies for the SDP are Li-ion, Lead-acid and NaS batteries. In theory, all three batteries can provide all the listed services with higher or lower efficiency. In the reality there are several barriers that prevent an ES, like a battery, to provide more than just a few of them. Because of varying reasons, several services are at this stage discarded as possible provided services at the SDP. This chapter will give a motivation to which these services are and why they are discarded.

Two of the umbrella groups, transmission and customer services, are discarded directly.

The transmission grid in Portugal is defined as the grid with a voltage between 150 kV to 400 kV. Redes Energéticas Nacionais (REN), the TSO in Portugal, is the public company exclusively responsible for this grid in Portugal (REN, 2012). Around the SDP there is no transmission grid available which rules out the option to provide the transmission services for an ESS at this location.

Customer services are generated with ESS on, or close to, the site of the consumer. The ESS provides the option to buy and sell electricity on the spot market as well as increase both the quality and the reliability of the electricity (ESA, 2016b). The services that are generally defined as a customer service are power quality, power reliability, retail energy time-shift and demand charge management (Akhil, et al., 2015, pp. 21-26). The SDP is primarily a producer and not a consumer of electricity and with this definition, the customer services do not apply for an ESS designed for a large scale-generating unit.

For this report, no data could be gathered regarding the distribution grid owned by Energias de Portugal (EDP). This circumstance rules out the possibility to perform simulations of voltage support, frequency regulation, spinning, non-spinning and supplemental reserve and also distribution upgrade deferral. Uncertainties about the ideal placement of an ESS that could provide any of the services is another factor that was taken into consideration when discarding these services.

Black start is a service that a battery can provide in addition to other services but never as the main service. As a consequence, an ESS will rarely be optimized for this service (RMI, 2015). Because of the fact that the emphasis of this thesis is to design and optimize an ESS for different services, the black start service will not have any impact on the final technical result and it was thereby discarded.

The bulk service, electric supply capacity, is in the short context, the service that provides a backup if the load exceeds the production on the grid. With the fact that no data was collected regarding the local distribution grid or the local loads, these services were discarded. Also, the fact that the SDP is the main generation unit on a distribution line with a probably much lower load profile strengthened this decision.

3.3.4 Review of Possible Services for the SDP

Today, the cost of implementing an ESS that only provides one single service nearly exclusively exceeds the benefits. The most appropriate way to provide an ESS, where the benefits are greater than the costs, is the so-called stacking of services. This means that the more services the ESS can provide, the better is the economic forecast and the motivation to implement a new technology (EPRI, 2013).

California Public Utility Commission (CPUC) has categorized different use cases with different services to provide a general picture of viable options. Important to point out is that an accurate economic evaluation is hard to perform of the stacked up services because a simple sum does not display the true value. This is explained by the fact that all services cannot be provided at the same time and also differ depending on the time of the day and year (Akhil, et al., 2015, pp. 26-27).

After 15 of the services, defined by (Akhil, et al., 2015), were discarded, three are remaining. Two of them, load following/ramping support for renewables and regulation, are today services that can provide benefits to the grid. As of today, the benefits of these services spell out rather in terms of functionality, than in direct revenue. However, this balance is bound to change with further RE introduction.

The last service, electric energy time-shift (arbitrage) is on the opposite chosen to provide direct economic value for to SDP and the ESS.

3.3.4.1 Load Following/Ramping Support for Renewables

Load following/ramping support for renewables is the name of this service defined by (Akhil, et al., 2015) As already mention in the previous chapter, no data was gathered regarding the load profile at the distribution grid. This results in that this service only will treat ramping support for renewables. In addition to the name “ramping support for renewables” this service is also named ramp-rate control, ramp-rate smoothing, ramping support and ramp-rate limiting service. However, from this stage on, this service will only be called ramping support.

Ramping support is chosen because the authors think that this ability will continue to grow in importance for ESS connected to intermittent power generation. With higher penetration of wind and solar power, the fast ramp up/down events will be increasingly problematic for grid operators, and may disturb power quality and reliability of the grid (Marcos J. , Storkel, Marroyo, Garcia, & Lorenzo, 2014). Trends can be seen that grid operators declare requirements for smoother ramping for the connection of new intermittent sources (McKeon, Furukawa, & Fenstermacher, 2014). This is seen as a possible future system-wide requirement on regulatory level. The events of extreme output ramping are hard to forecast. This is one of the reasons why ramping support is chosen as the highest prioritized service in our base case. However, it should be mentioned that no regulations regarding maximum ramp rates have been implemented for the Portuguese electricity market, as of today.

According to (Akhil, et al., 2015), a DEES able to provide ramping support could also provide voltage support and other distributed applications and has synergies with services like electric supply capacity, peak shaving and electric energy time-shift (Akhil, et al., 2015, p. 47). An ESS that can provide ramping support has also the ability to provide voltage support for the local grid in terms of reactive power (EPRI, 2010).

3.3.4.2 Regulation

As stated in chapter 3.3.1.2 *Ancillary Services*, regulation is defined as an ancillary service by (Akhil, et al., 2015) It is stated that the “*Regulation is used to reconcile momentary differences caused by fluctuations in generation and loads*” (Akhil, et al., 2015, p. 55). One way to harmonize a highly fluctuating generation, as from the SDP, is to remove the peaks of electricity generation, and absorbing energy from the generation unit that exceeds a certain power output. This service is generally defined as “peak shaving” but has also been discussed under other names. This report will, from this stage on, treat the ancillary service of regulation, as peak shaving for simplicity reasons.

Peak shaving is chosen as the service in second priority, mainly because of the anticipation of a future expansion of the SDP. As Enercoutim is continuously working for an increasing installed capacity on the site, the authors think that a growing peak output will become a reality, only as a matter of time. This development will sooner or late require upgrades of the grid equipment e.g. export cables, breakers, switchgear and transformers, upstream from the platform connection point. However, to postpone this investment, a BESS can be an alternative to provide this service (ABB, 2016).

3.3.4.3 Electric Energy Time-Shift (Arbitrage)

Arbitrage is a control strategy to maximize income per produced MWh, and to shorten the payback time of the ESS. This service will be provided as the last prioritized service, since the nature of the service is “the more the better” in terms of energy dimension. However, it should be mentioned that this service is applied for a hypothetical future state, when a more dynamic, electricity market has been adapted. At the time of writing, special static feed-in tariffs still apply to every MWh produced at the SDP, which is discussed further in the next chapter.

3.4 Investment Environment

ESS can already today provide economical valuable ancillary, transmission, distribution and customer services, but in general, ESSs are still considered expensive. The International Energy Agency (IEA) has presented a list of key actions to increase the market share of ESS. The proposed main actions are to support new investments, learn from existing projects, create international databases and to standardize and to quantify the actual value of the services the ESS can provide (IEA, 2014).

In terms of economy, the focus in this report will be on the ES technologies levelized cost of electricity (LCOE), the capital cost per MW and MWh, and the value of services today and in the future. Because of the lack of a global database summarizing the cost and values of different ESS and their corresponding services, the presented numbers and graphs in this chapter should be read as an indication, not as the only viable cost or value. Another fact leading up to this conclusion is that the cost and value of ESS and services are highly location dependent. Based on which organization, institute or company that presents the numbers of the cost and the values for ESS, the way of calculation and gathering of data will differ. Naturally, this leads to different conclusions regarding the final number. In addition, the value and cost can be expressed in many different ways. A common way to present these figures is in American dollars or euro, per energy unit, expressed as kWh, and per power unit, expressed as kW. This constitutes the standard used in this report (Akhil, et al., 2015, p. 64).

Because of the differences in calculation method and data, the presented numbers in this chapter are collected from a variety of sources. These have often taken different other reports into consideration and then present their own graphic of their result. This gives the report a more balanced economical view, even if only one single source is presented. This approach also gives a useful screening tool for comparing different technologies and services.

3.4.1 LCOE, Cost/kW and Cost/kWh of BESS Today and in the Future

LCOE is the most suitable economic indicator to compare different ES technologies for an investment (European Parliament, 2015). The LCOE takes into account the annualized capital cost, operation and maintenance, replacement of the ESS, recycling cost together with the numbers of discharge cycles per year and discharge time per year. The annualized cost also takes into account the lifetime of the ES, the interest rate, the capital recovery factor and the overall efficiency of the ESS. According to (Zakeri & Syri, 2014), the LCOE is very sensitive to discharge time, i.e. the time the ES is actually used. It is also important to make it clear that the LCOE may vary a lot for the same ES depending on study (Zakeri & Syri, 2014). This is why the LCOE is presented as an interval in Table 3-6.

As mentioned before, the calculation of the LCOE depends on several uncertain variables. To perform a valid calculation of the LCOE for this specific study, it would probably increase the uncertainties even more. Also, this does not fit the scope of the study. Instead, this thesis will provide a description of how the calculation of LCOE works and will then use the calculated LCOE intervals from three different studies to compare Li-ion, Lead-acid and NaS batteries. The three compared studies have expressed their LCOE in both EUR and American dollars for different years. To be able to compare the different LCOE, all the numbers in Table 3-6 are converted. The costs are first converted to EUR for the years the reports were written and then converted to the exchange rate of EUR for 2016. The exchange rates for each year are

an average of the lowest and the highest value of the specific year. The calculated exchange rates are presented in Appendix A.

Table 3-5. Explanation of the different variables used in equation 3.1 to calculate the LCOE.

Variable	Explanation
$C_{cap,a}$	Annualized main items in capital cost of ESS. In this the power conversion system, the storage section and the balance of plant are included.
$C_{O\&M,a}$	Total annual operation and maintenance cost.
$C_{R,a}$	Annualized replacement cost of ESS.
$C_{DR,a}$	Annualized disposal and recycling cost.
n	Numbers of discharge cycles per year
h	Discharge time per year

Equation 3.1 presents how the LCOE is calculated specifically for ES. Table 3-5 is providing an explanation of the different variables (Zakeri & Syri, 2014).

$$LCOE = \frac{C_{cap,a} + C_{O\&M,a} + C_{R,a} + C_{DR,a}}{n * h} \quad (3.1)$$

Table 3-6. The LCOE of the considered BESS technologies. All the LCOE are expressed in EUR of the average exchange rate 2016 (Akhil, et al., 2015) (Zakeri & Syri, 2014) (IRENA, 2012).

LCOE [EUR/kWh]	NaS	Li-ion	Lead-acid
SANDIA 2015	0.23-0.26	0.09-0.98	0.09-1.07
IRENA 2012	0.05-0.15	0.30-0.45	0.25-0.35
Zakeri & Syri 2014	0.24-0.25	0.42-0.61	0.25-0.31
Min	0.17	0.27	0.20
Max	0.22	0.68	0.58
Average	0.20	0.48	0.39

As can be seen in Table 3-6, the intervals of the LCOE are different between the three reports and so is also the magnitude of the intervals. This is partly explained by the fact that every report has different input data from different manufactures. Also, they compare the BESS types for different power output, discharge time and services. Common for the LCOE presented in Table 3-6 is that only bulk, transmission and distribution (T&D), utility and frequency services have been compared. Applications that need batteries for customer services have been excluded because of irrelevance for the SDP.

The LCOE of the BESSs provides a comparison that contains uncertainties. In order to choose the optimal battery it is important that technical and project specific details are evaluated carefully. The optimal cycle numbers to get the highest revenue based on state of charge and service requirement is a key factor here (Zakeri & Syri, 2014).

In a report from the International Renewable Energy Agency (IRENA) 2014, *Technology Roadmap – Energy storage*, another estimation of the LCOE is presented. The results are shown for seven ES technologies where NaS, Li-ion and Lead-acid batteries were included, see Figure 3-7. The figure

illustrates the intervals of the LCOE 2013 for the ES techniques and also shows the cost target for the two-degree scenario, along with the breakthrough scenario 2050 (IRENA, 2014). The values are in USD 2013 per MWh but with energy unit conversion and economical conversion rates (Appendix A), the numbers are in line with Table 3-6. According to the figure, Lead-acid and NaS batteries are closer than Li-ion to a breakthrough scenario but still behind pumped hydro (PHS) and CAES.

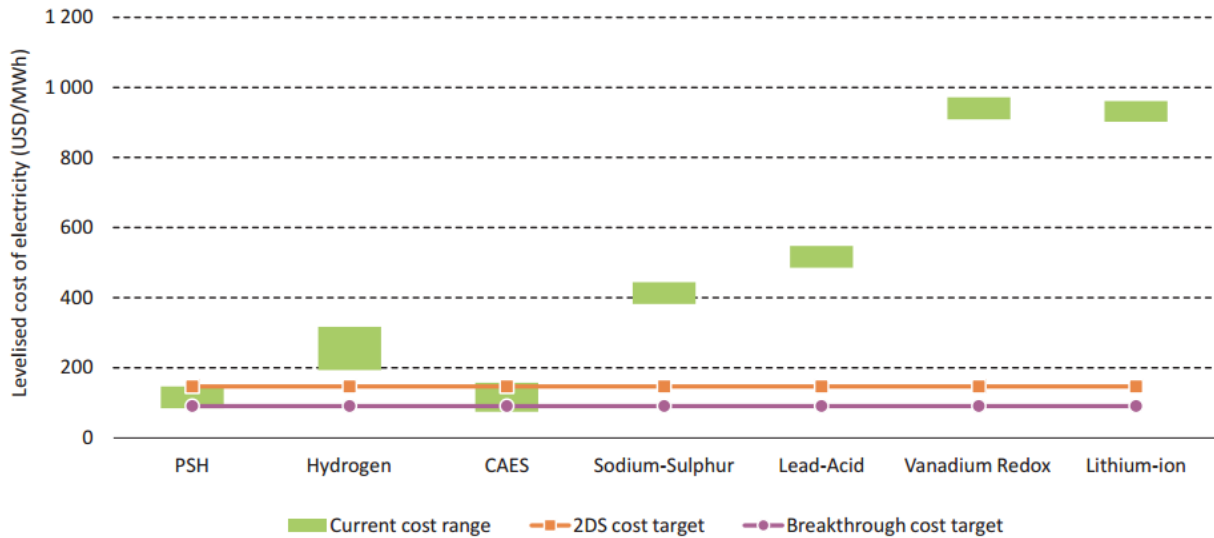

Figure 3-7. The LCOE in current cost range (2013) and breakthrough scenarios until 2050 expressed in USD/MWh (IRENA, 2014).

Another common way of compare ES in cost is to determine the capital cost per kW and per kWh. Deutsche Bank has in their market research for the future of the solar power, summarized the capital cost for ES today and also how they predict costs will drop in the future. For example, the LCOE for BESS in combination with solar power is forecasted to decrease from 0.33 \$/kWh today to 0.06 \$/kWh 2021. Table 3-7 shows the capital cost interval for Li-ion, NaS and Lead-acid batteries (Deutsche Bank, 2015).

Table 3-7. The capital cost for Li-ion, NaS and Lead-acid batteries in terms of EUR per kW and kWh (Deutsche Bank, 2015).

Type of BESS	EUR/kW	EUR/kWh
Li-ion	963-3641	799-5506
NaS	2753-3552	395-493
Lead-acid	844-5150	311-3374

The capital cost intervals are considerable, especially for Li-ion and Lead-acid batteries, but more condensed for NaS batteries. NaS batteries are according to Table 3-7 the best alternative for a battery with an emphasis on energy instead of power. Li-ion is the opposite, where the interval per kWh is very big and always above NaS. The capital cost interval per kW for Li-ion is also significant, but with the lowest average cost. Lead-acid has a big capital cost intervals both in terms of EUR per kW and kWh but also the lowest presented capital cost in both categories.

In order to calculate the total capital cost of a BESS, equation 3.2, 3.3 and 3.4 are used. The capital cost per stored energy and the rated power (conversion system) is first calculated by multiplying the cost per kWh and kW (Table 3-7) with the required energy and power needed for the BESS. These required energy and power dimensions will depend on the chosen provided service. The total capital cost is simply the sum of the capital cost of energy and the capital cost of power (Zagoras, 2014).

$$Capital\ cost_{Energy}[EUR] = Cost\ per\ kWh[EUR/kWh] * Req.\ Energy_{BESS}[kWh] \quad (3.2)$$

$$Capital\ cost_{Power}[EUR] = Cost\ per\ kW[EUR/kW] * Req.\ Power_{BESS}[kW] \quad (3.3)$$

$$Capital\ cost_{Total}[EUR] = Capital\ cost_{Power}[EUR] + Capital\ cost_{Energy}[EUR] \quad (3.3)$$

The predicted drop in capital cost per kWh is illustrated in Figure 3-8. The price will, according to Bloomberg New Energy Finance (BNEF) and Navigant, drop drastically the next years and continue down to 100 USD/kWh. IEA also predicts a drop in cost for BESS but not of the same magnitude. The average between the three studies result in a cost reduction that 2022 will be equal to 350 USD/kWh, which today is about the lowest possible cost for any of the BESS presented in Table 3-7.

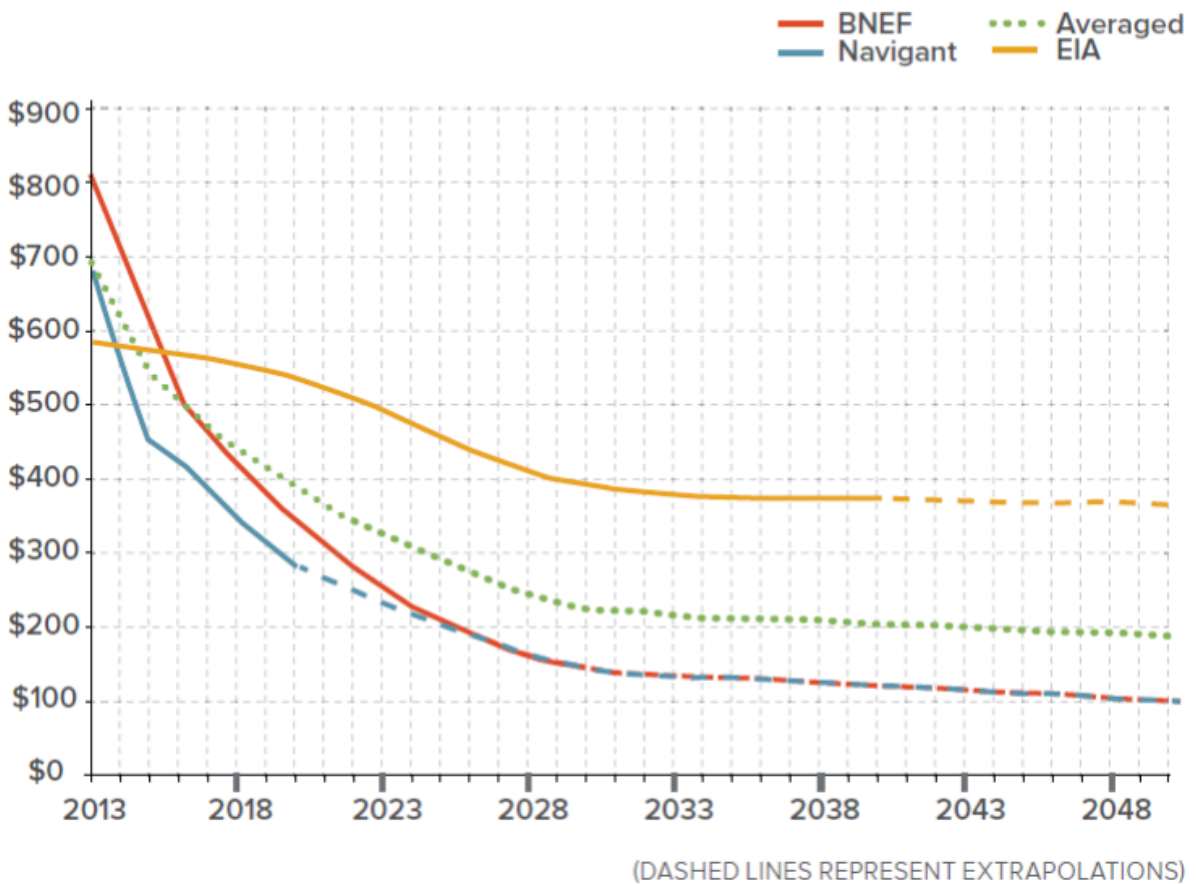

Figure 3-8. Prediction of the cost reduction of BESS in the future according to three sources. Y-axis is USD/kWh 2012 (Deutsche Bank, 2015).

The CPV clients at the SDP use a feed-in tariff system to sell their produced electricity. The feed-in tariff is 0.35 EUR per kWh and valid from the CPV system was installed and 12 years ahead. The CPV produced electricity has always the priority to be sold to the grid, even when the demand is low. The revenue the CPV clients get for the produced electricity is thereby calculated with equation 3.4 according to João Correia de Oliveira. 2 MW_p was installed simultaneously 2013, another 1.27 MW_p 2014 and the last 1.23 W was installed 2015. This means that the fee-in tariff will stop to be used 2025 for 2 MW_p and 2026 and 2027 respectively, for the last 2.5 MW_p (Enercoutim, 2016b).

$$Revenue [EUR] = 0.35 [EUR/kWh] * produced\ electricity[kWh] \tag{3.4}$$

3.4.2 Overview of Service Values Today and in the Future

ESSs can provide a wide range of services. However, one interesting question connected to this is of course what are the services worth and to whom?

This is a highly discussed question with no clear answer. Depending on which country and region the ES is located in, the same service can have completely different values. Many factors come into play e.g. the placement of the ES in the grid system, specific capacity bottlenecks, existing markets for one type of service and regulations, to mention a few. Figure 3-9 is retrieved from Rocky Mountain Institute (RMI) that has given out the report “The Economics of Battery Energy Storage”. Herein 13 different reports are compared as to how they value the same service (RMI, 2015). As can be seen in the figure below, the values are varying a lot and especially regarding transmission and distribution deferral.

With a greater amount of RE fed into the electrical grid, problems with its intermittence will open new market in the future. This is particularly true for remote areas where an installation of an intermittent power source can cause fluctuation in the distribution grid, which will lead to new investments for the grid (IRENA, 2014). With Enercoutim’s aim of developing the SDP even further in terms of power producing units, the distribution grid and electrical components will at some point need to be upgraded. This will change the value for different services in favour for the ESS.

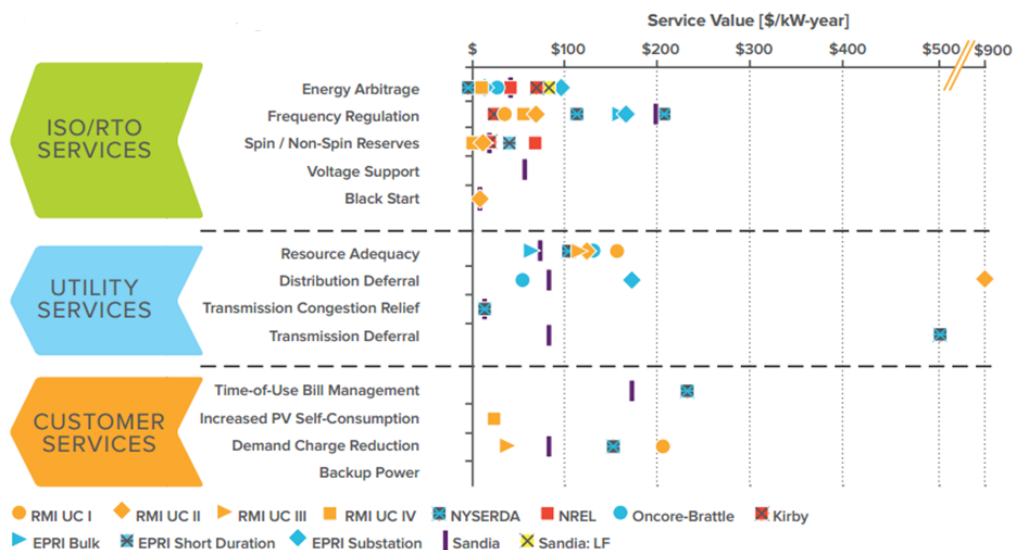

Figure 3-9. The values of different services is presented according to 13 leading studies (RMI, 2015).

3.5 Literature and Case Review

The installed capacity of traditional PV cells is increasing in the world, both for big scale and small-scale generation, in line with their reduced cost. With the increase of intermittent energy generation the number of ESSs have also increased. When disregarding pumped hydro and thermal storage, the electro-mechanical family of energy storage is still the most common in terms of installed capacity. However, the installation of electro-chemical technologies have increased from 0.1 GW to 0.8 GW the last 10 years and are soon at the same level as electro-mechanical storages (DOE, 2016b).

With the increased installed amount of both PV, electro-mechanical and electro-chemical ES, a great number of studies have been performed regarding the combination of these technologies. The CPV technology is a newer technology compared to PV and it was first 2012 when the yearly amount of installed CPV exceeded 20 MW (NREL, 2016).

With a generation technology that just recently has been installed in greater amount, there are few studied made on the combination of CPV and ESS. For this report it means that the majority of the studied cases in this chapter are about the combination of wind power and traditional PV with ESS and not the actual combination with CPV and ESS. Nevertheless, because of the similarities between PV and CPV in terms of energy production the PV related articles are still interesting for this study.

3.5.1 Existing PV, BESS and Service Combinations

There is a wide range of ES technologies and services used globally today and there is also a variety of different definition and affiliation of the services. To further evaluate which BESS and services that are the most common today, different articles have been reviewed and case studies are compared.

According to (Malhotraa, Battke, Beuseb, Stephanb, & Schmidta, 2015) ESS has recently got more attention from the industry and politics. Especially batteries have gotten a push in the right direction lately. Batteries with their modularity, scalability and diverse arsenal of services, are today installed from large-scale grid solution to small-scale solution with varying responds time. Among the grid-connected batteries on the mainland, the most common services, when disregarding consumer and transmission services, is frequency regulation, 16 %, followed by Load Following/Ramping support for RE (generation level), 14 %, electric energy time shift (arbitrage) at a generation/grid level of 14 % and voltage support at 3 % of the total cases. It is also stated that there is a big variation between regions and countries in terms of share of a certain service. In European countries the power quality of the grid stands for the biggest service share, but in most part of the USA and Japan arbitrage for consumer and generation/grid makes up the biggest part.

3.5.2 Comparative of Case Studies

Today there are in total 515 operational grid-connected ESS of the electro-chemical, electro-mechanical and hydrogen type, with a total installed power of 2.11 GW (DOE, 2016b). This would in theory enable the possibility of 515 case studies.

USA is the country in the world with most BESS, both in terms of projects and in installed capacity. Following this, many case studies have been carried out here (DOE, 2016b). (Subburaj, Pushpakaran, Bayne, 2015) present, in their overview of grid connected BESS, several of these systems in combination

with intermittent energy production. Included in the report, the solar technology acceleration centre (TAC) installed a 1 MW, 1 MWh Lead-acid dry cell battery 2011 to 2013 in order to test the BESS for the ability for ramping support. This service was aimed to smooth out the PV production and to optimize the PV output. The installed capacity for that PV facility is 4.5 MW, which is the same as the installed capacity of the SDP today. The fact that this company is testing different services in provided by a mature ES at a PV site makes this case interesting to compare with. The downside, in terms of comparison, is the fact that the site use PV instead of CPV and that the facility is located in USA.

According to (Malhotraa, Battke, Beuseb, Stephanb, & Schmidta, 2015) it is important to understand that a certain service could bring a high value for one location but not for another. This can be the case due to the geographic differences, differences in policies, etc. The conclusion of the report is that Lead-acid generally is the best solution because of its low cost and maturity. (Subburaj, Pushpakaran, Bayne, 2015) continue with the statement that Ni-Fe, redox-flow and NaS batteries also provide several benefits with its long lifetime and relative low LCOE. Li-ion batteries are concluded to be very interesting with its high energy density and flexibility, but are in most cases considered as expensive and complex.

Table 3-8. The numbers is gathered from DOE for grid-connected ES between 1 MW and 10 MW in connection with PV or CPV panels (DOE, 2016c). The Na-Ni-Cl battery in Italy is an exception because of the connection with a CPV site.

Site	BESS	MW	MWh	Services
Vacaville, USA, PV	Na-S	2.0	14.0	<ul style="list-style-type: none"> • Electric Energy Time Shift (Arbitrage) • Electric Supply Reserve Capacity - Spinning • Frequency Regulation • Load Following/Ramping support for RE
Longgang, China, PV	Li-Fe- PO_4^{3-}	1.0	4.0	<ul style="list-style-type: none"> • Load Following/Ramping support for RE • Electric Energy Time Shift (Arbitrage)
Seville, Spain PV	Li-Ni-Ma-Co	1.0	0.2	<ul style="list-style-type: none"> • Electric Supply Reserve Capacity - Spinning • Frequency Regulation • Load Following/Ramping support for RE • Voltage Support
Mare Poirier, Martinique PV	Li-ion	2.5	0.8	<ul style="list-style-type: none"> • Load Following/Ramping support for RE • Renewables Energy Time Shift (Arbitrage)
La Jolla, USA PV	Li-Fe- PO_4^{3-}	2.5	5.0	<ul style="list-style-type: none"> • Renewables Energy Time Shift (Arbitrage) • Retail Electric Energy Time-Shift (Cust. Service)
Yokohama, Japan, CPV	Vanadium Redox Flow	5.0	5.0	<ul style="list-style-type: none"> • Retail Electric Energy Time-Shift (Cust. Service) • Load Following/Ramping support for RE • Electric Supply Capacity
Sardinia, Italy, CPV	Na-Ni-Cl	0.3	0.4	<ul style="list-style-type: none"> • Ancillary Services at Distribution Level

As seen in Table 3-8, there is a considerable diversity, both in terms of technology type, and the power to energy ratio between the cases. When considering the services they provide, the picture is different. The majority of the BESSs provide the service of load following/ramping support for RE and retail electric energy time-shift (arbitrage). It is also clear that the BESSs provide more than one single service, i.e. stacking the services. This table does not represent the entire grid connected BESS between 1 to 10 MW but they provide an interesting comparison of chosen technology, together with power to energy ratio for different services.

4 Design Method – Simulation

Three methods to optimize an ESS in combination with the services ramping support and peak shaving have been reviewed in order to create a reliable work method and to compare key parameters.

This chapter will feature the method that was used to obtain the result presented in chapter 5. The following subchapters are first discussing how different methods have tackled similar problems and what we can learn from them. Thereafter the control strategy of the BESS is explained, with an accompanying flow chart. The chapter ends with the presentation of the used simulation model and a discussion of the used input data. A critical view on the used method is applied and discussed throughout the whole chapter.

4.1.1 Method for BESS Sizing

In a report from (Marcos J. , Stork el, Marroyo, Garcia, & Lorenzo, 2014) a method for dimensioning an ESS for ramp rate control of a PV plant of any size is presented. For their study they analysed different sized sections of the 38.5 MW PV plant in Amareleja, Portugal. This site is located less than a 100 km (bird's way) northeast from the SDP. Simulation for required battery characteristics are carried out with 5-second resolution for the power output data. Functions for required ESS rated power and energy capacity are retrieved. These are then validated through applying them to two Spanish PV plants, 600 km away, and analysis of their ramp requirements. The maximum ramp rates caused by different sized PV plants are formulated as to be dependent on the shortest dimension of the perimeter of the PV array. The study also concludes that a smart SoC control is important for a better use of the battery and that ramping support could be combined with other services e.g. frequency control and time shift to maximize its value.

(Marcos J. , Stork el, Marroyo, Garcia, & Lorenzo, 2014) also derive a general formula to calculate the required battery power and energy depending on the installed power rating of the solar platform. With help of equation 4.2, the required battery power is calculated. Correspondingly, with equation 4.3 the required energy is calculated. P^* represent the installed capacity in MW, τ is the time variable expressed in seconds that is calculated with equation 4.1, and dependent on the shortest perimeter of the PV plant, l , expressed in meter. The parameter a (0.042 sec/meter) and b (-0.5 sec) is empirical determined constant derived from observations in Amaraleja in Portugal.

$$\tau = a * l + b \quad (4.1)$$

$$P_{BAT,MAX}(t) = \frac{P^*}{100} \left[90 - \tau * r_{MAX} * \left(1 + \ln \left(\frac{90}{\tau * r_{MAX}} \right) \right) \right] \quad (4.2)$$

$$E_{BAT,MAX} = \frac{0.9 * P^*}{3600} \left[\frac{90}{2 * r_{MAX}} - \tau \right] \quad (4.3)$$

Rob van Haaren has assessed the solar variability and ESS optimization in terms of ramp rate control from six PV plants in the USA and Canada. The plant sizes are ranging between 5 MW and 80 MW. Van Haaren's theory and observations conclude that the power to energy ratio of an ESS that provides the

service of a maximum ramp rate of 10 % of installed capacity per minute (i.c./min) is 12:1. It was also concluded that the ratio is much lower if the maximum ramp rate is changed to 5 %. Compared to (Marcos J. , Storkël, Marroyo, Garcia, & Lorenzo, 2014) van Haaren also comes to the conclusion that the larger the solar platform is, the smaller is the power output fluctuating because of passing clouds. The size of the solar facility also has a great impact on the numbers of times the ramp rate exceeds (violates) e.g. 10 % of i.c./min. For a 5 MW PV facility, the numbers of violations above 10 % of i.c./min was 8700 for one year but only around 2700 for an 80 MW plant. The study also concludes, like (Marcos J. , Storkël, Marroyo, Garcia, & Lorenzo, 2014), that ESS that provides ramping support can provide services i.e. frequency regulation and load following (Haaren, R, 2014).

To optimize and choose the ES technologies for peak shaving solar and wind power profiles, (Nykamp, Molderink, Hurink, & Smit, 2013) have come up with another method. This method shows that it is important to find the optimal power to energy ratio in order to dimension the ES. It is also important to minimize the numbers of charging cycles, in order to increase the lifetime of the ES. The power to energy ratio is depending on how big and how extended the peaks are that are aimed for to be avoided. To reduce the numbers of charging cycles the study proposes to enable frequent but small charging cycles instead of few bigger ones. (Nykamp, Molderink, Hurink, & Smit, 2013) further discusses that medium charge term oriented ES, like batteries, work well to store electricity for PV plants. This is mainly because the output peak only last for at most several hours and not for a day or longer like in the case for wind power. Li-ion batteries are recommended to handle this service for PV plants according to the study.

The method that will be used to perform the simulations to find the optimal design for the BESS is based on a weighting between which services that are highest valued for the SDP, and for the local DSO. This weighting resulted in a prioritization list where ramping support is prioritized first, peak shaving as the second and arbitrage as the least prioritized service. The three different BESSs, Li-ion, Lead-acid and NaS batteries have the capability to provide all these services and will thereby be simulated in the same model.

In order to understand how the BESS will perform during the services, simulations will first be performed for each service separately for the most extreme day, according to this service. The aim of this was also to see how each and every service would affect the required dimensions. When this had been performed, simulations were carried out with the three services combined for the full month of September 2015. The simulations will test different key parameters to give a result for how the BESS needs to be dimensioned.

The reviewed methods present interesting key parameters that will be simulated for and evaluated. Because all three reports only base their result on one single service, the key parameters were also compared after deriving the result from the simulation of each service separately. When performing simulations with all three services combined, the goal is to find the optimal solution to cater for all of the key parameters as much as possible.

To be able to run simulations, a robust model in an electric simulation tool was built. The model is constructed by the authors in the open source simulation tool OpenModelica with the help of the supervisor at Lund Technical University.

4.1.2 Overview of BESS Control Strategy

The flowchart shown in Figure 4-1 describes the control strategies for the control of the BESS in order to provide the three chosen services. The flowchart is simplified to give a comprehensible overview of the whole system.

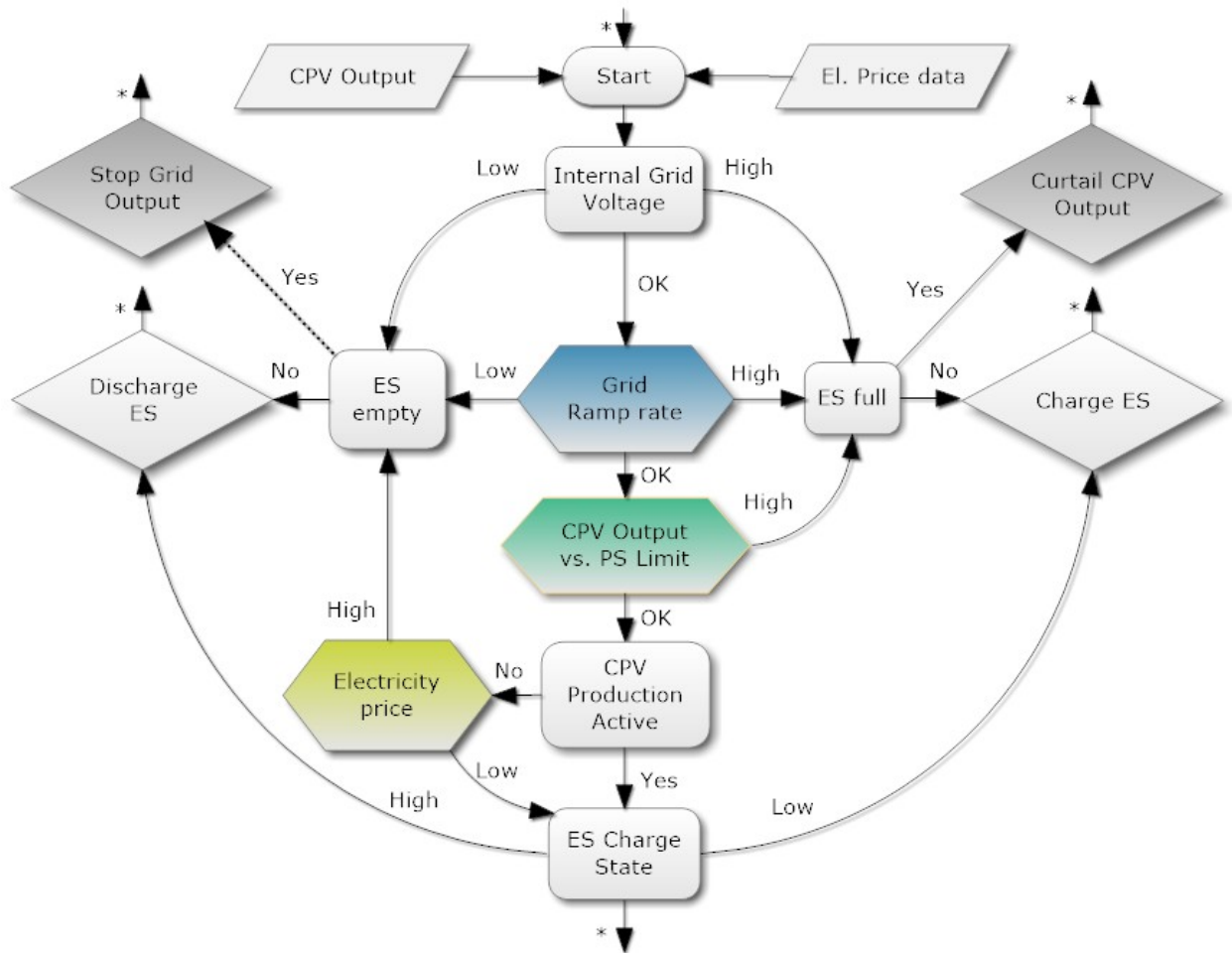

Figure 4-1. Flowchart showing the overview of the BESS control strategy.

Before every calculatory iteration, input data is read, both from the CPV Output file and the data for electricity price. What follows after the starting point is a hierarchical order, where the controls further to the top are prioritized before the control paths towards the bottom.

The control for the internal grid voltage is always active, and tries to keep this voltage close to a set point. The coloured symbols represent the key triggers for the individual services. In the grid ramp rate, as the name suggests, the ramp rate experienced by the grid is controlled in order to not exceed the set limits. The following control is the one for peak shaving, where the CPV Output is compared against the set peak shaving limit. Arbitrage is the lowest prioritized service. This is only activated in times when there is no production from the CPV, and it has only the authority to discharge the ES. This happens

when the price signal exceeds the set selling price limit (and there is energy in the ES). The ES charge control makes sure that there is always enough energy, or empty storage capacity, in the battery to mitigate negative and positive worst-case ramp rates respectively. A further description of the control system is found in the following section, explaining the OpenModelica model.

4.1.3 Building the Model

The system that is used to perform the simulation for this thesis is presented in Figure 4-2. The entire electrical model is constructed on the basis of direct current (DC). This is not the case in the real world system, where each tracker's converter unit converts its CPV output to 0.4 kV alternating current (AC). From there on and upstream to the export cables, the real system runs on AC. However, a number of simplifications were necessary in order to be able to create a functioning, smoothly running model within the timeframe of the thesis project. This simplification was done in agreement with the project supervisor, and it is believed not to affect the model outcome significantly. Along with regarding the whole system as a DC system, resistances across the whole platform are neglected. Consequently, all types of grid losses are disregarded. However, the CPV output data account for parts of the internal grid losses. Nevertheless, types of simplifications should naturally be regarded as relevant sources of error.

The system contains four main areas, one including the energy storage, one the power production from the CPV, one part with the external (distribution) grid and one part with the control units interacting between the internal system and output unit to the external grid. The model is built to resemble an internal and one external grid connected to each other through a busbar. The internal grid, which includes the CPV and storage area, is constructed to always strive to maintain a voltage level of 1 000 volt.

The energy storage area consists of a storage unit, a DC/DC converter, a control unit, a sensor unit, a PID-regulator and a set value. The storage unit is connected to the DC/DC converter, which functions as the switchgear required to direct DC power in and out from the unit. In reality, this converter would represent the break point between DC and AC, since batteries always run on DC. The converter is in turn connected to the sensor unit. The sensor unit measures the voltage and the current, multiplies these values to get the power output/input to the storage. These values can be provided as inputs signals to other components. The controller unit, S-controller, is the device specifying what the limits and start values of the energy storage should be. Also it keeps track of the energy level of the ES. To the right of the S-controller is a PID regulator and a constant value source located. The purpose of this pair of units is to regulate the voltage of the internal grid (kept around 1000 V).

The CPV model area consists of the input data table, a power source, a sensor unit and control units. The CPV output data is read from a text file connected to the table unit to the far left. The power source next to it receives these signals and outputs the corresponding currents. To the right of the power source a sensor is located (same as mentioned above) which provides a voltage input to the control units above. The purpose of these units is, among others, to cut (curtail) production in case the internal grid voltage rises above 1100 V. This could happen when the ES has reached its upper energy level and cannot absorb more incoming energy from the CPV trackers.

The grid area is made up of a voltage source, two sensors, a DC/DC converter and a PID regulator. The grid voltage source is considered as being the connection point to an infinitely strong grid, which is also ground-connected. The sensors are of the same type as mentioned earlier. The DC/DC converter is the final unit dictating at what power rate the energy from the internal system should be delivered onto the external grid. The converter receives its input signal from the PID regulator, which is capable of varying the maximum ramp rates and peak shaving limits for the system.

The control unit area contains, other than ramp rate control and peak shaving, a number of the algorithms making it possible to a) further define operational strategies for the system and b) extracting operational data from the system. A busbar connected to a sensor can be seen. The busbar represents the electrical intersection between the systems three main components, the ES, CPV and external grid. The sensor is of the same type as described earlier. In the G-controller, an ES discharge power (discharge to the external grid) can be set to be activated whenever the ES reaches or gets close to its upper energy level. Finally, the arbitrage controller receives the grid electricity price data from a text file, and with the help of threshold price signals and the current energy state of the ES, decides if stored energy should be sold or kept for later.

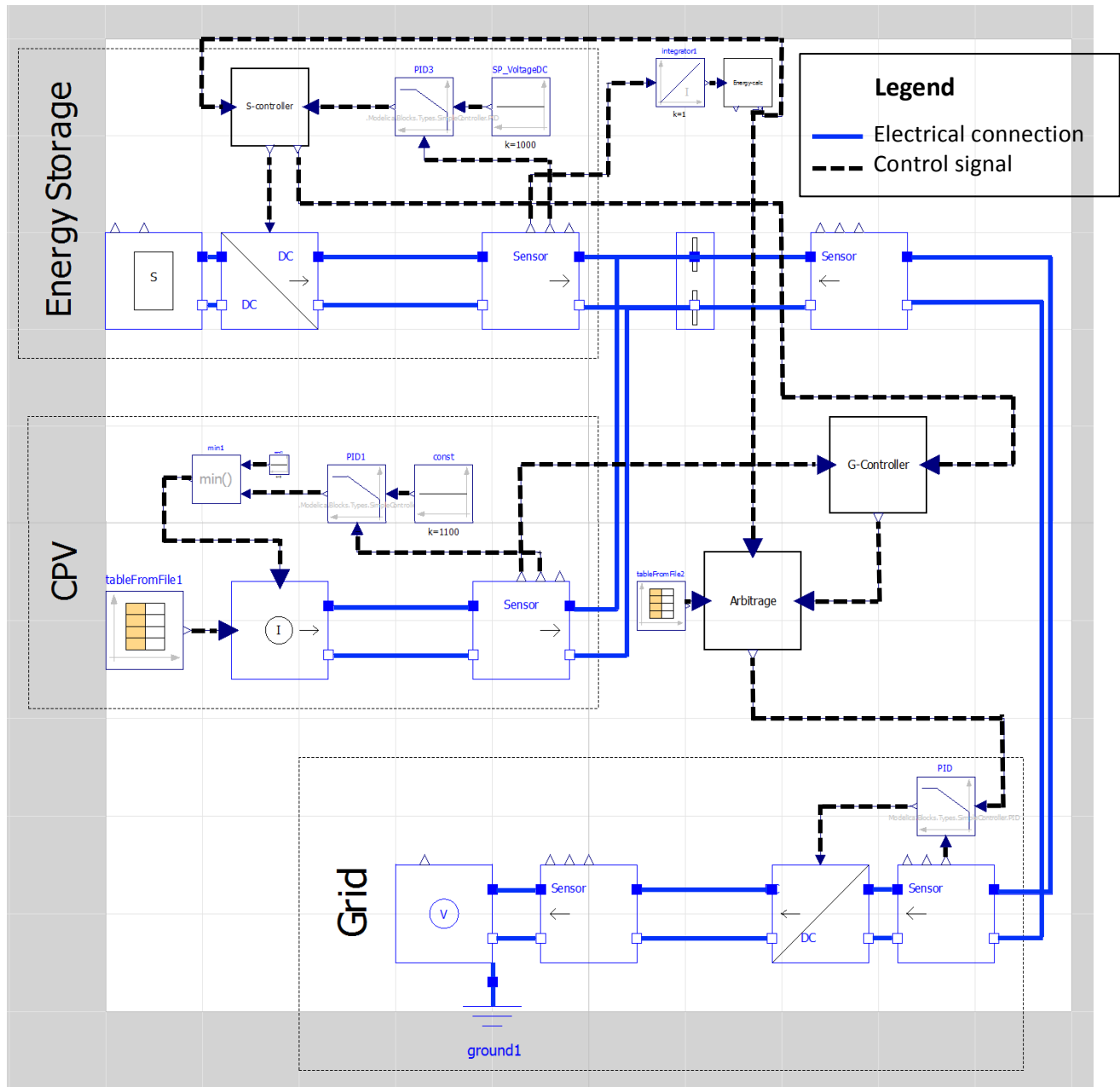

Figure 4-2. Illustration of the model used in OpenModelica for the combination of the three services.

4.1.4 Input Data

4.1.4.1 Ambient Temperature

The temperature data that was used to calculate the temperature of the cells (T_{cell}), see Table 4-1, are hourly values derived from the program Climate Consultant 6.0. The temperature data was gathered at Alcoutim, 30 km away from the SDP, for September 2015. The ambient temperature is affecting the efficiency of the CPV cells but small temperature differences have small impacts of the total output. Because of this statement, the temperature values are assumed to be constant for the whole hour.

4.1.4.2 DNI Values

The DNI values are derived from a DNI meter at the University of Évora in the south of Portugal. The dataset consists of DNI values from September 2015 and have a resolution of 1 minute. The metering unit records values on 1-second basis in order to calculate and save average minute values. Unfortunately, the second values are not stored, thus 1-minute values pose as the highest available resolution.

3 % of the total amounts of minutes are not measured because of maintenance, calibration or technical issues. The gaps are generally below one hour but at three occasions the gap without data is over one hour. With an error of only 3 % of the total amount of data points, the errors are assumed to have small impact on the total amount of energy produced over the month (Cavaco et al, 2015). To prevent any extreme changes in power outputs because of missing data, a replacement by a linear regression in DNI has been made for short time periods. Where the missing data exceeds one hour, the DNI data is assumed to be decline in a linear way to zero and then it stays there until the DNI meter starts measuring again.

That the DNI values are from Évora, which is located 128 km north from the SDP, is not optimal but acceptable. Évora is, as the SDP, located inland, in the southern half of Portugal and according to the solar maps from SolarGIS, both locations have the same average annual DNI (SolarGIS, 2015). This means that both the magnitude of the DNI and the variability should be in line with the real values at the SDP.

4.1.4.3 Price Data for Arbitrage

The price data used for simulating the arbitrage service is official data retrieved from the REN homepage (REN, 2016). REN is the TSO in charge of both the Portuguese and Spanish transmission grid. The gathered data set covers the whole of 2015, which is the same year as the recorded DNI values from Évora. The price is set on an hourly basis, therefore the price signals are shown as one-hour steps in the simulation diagrams.

4.1.4.4 Processing of Data

The power output from the SDP is calculated by using equation 4.1 (Antonio Luque, 2011). The total installed power at the SDP ($P_{SDP, installed}$), the maximum radiation (G_o), the power coefficient (δ_0), the reference temperature (T_{ref}) and the total losses (η_{tot}) are static values that are known and presented in Table 4-1. The DNI values from Évora (DNI_{Evora}) are measured for every minute during the whole month of September 2015. According to João Correia de Oliveira the weather for this specific month varied greatly which leads to power profiles with both a smooth power output and with shifting power output. This month was claimed to be the one with the greatest output variations.

The efficiency of the CPV cells is affected of the ambient temperature. Equation 4.2 is used to calculate the temperature of the cells of the CPV, which then is used in equation 4.1. There are additional losses until the electricity reach the ES, which is calculated according to equation 4.3.

$$P_{SDP} = P_{SDP, installed} * \frac{DNI_{Evora}}{G_o} * (1 + \delta_0 * (T_{cell} - T_{ref})) * \eta_{tot} \quad (4.1)$$

To calculate the temperature of the cells the static values of the normal operational temperature of the

cells (T_{NOTC}), the reference temperature of the air ($T_{air, ref}$) and the normal radiation stated by the manufacturer ($G_{ref, NOTC}$) are used together with the DNI values from Évora (DNI_{Evora}) and the hourly ambient temperature of the month of September 2015 (T_{amb}).

$$T_{cell} = T_{amb} * \frac{(T_{NOTC} - T_{air,ref})}{G_{ref,NOTC}} * DNI_{Evora} \quad (4.2)$$

The losses from the DNI absorption until the electricity reach the ES is the product of losses because of angular errors (η_{ang}), dirt at the cells (η_{dirt}), losses because of the inverters (η_{inv}) and the losses because of the internal cables at the SDP (η_{cab}).

$$\eta_{tot} = \eta_{ang} * \eta_{dirt} * \eta_{inv} * \eta_{cab} \quad (4.3)$$

Table 4-1. The full list of variables, and accordingly values, which was used to calculate the electricity production at the SDP with varying DNI and ambient temperature.

Specification	Formula variable	Value
Total installed effect at the SDP [W]	$P_{SDP, installed}$	4 506 000
Maximum radiation [W/m^2]	G_o	1000
Power coefficient of the CPV cells [-]	δ_o	-0.0016
Reference temperature [$^{\circ}C$]	T_{ref}	25
Angular losses [-]	η_{ang}	0.974
Losses because of dirt [-]	η_{dirt}	0.97
Losses because of inverter [-]	η_{inv}	0.95
Losses because of cables at the SDP [-]	η_{cab}	0.97
Total losses from the cells to the ES	η_{tot}	0.87
Normal operational temperature of the cell [$^{\circ}C$]	T_{NOTC}	70
Reference temperature in the air [$^{\circ}C$]	$T_{air,ref}$	20
Normal radiation stated by manufacturer [W/m^2]	$G_{ref,NOTC}$	800

The ideal scenario, in order to perform the best simulations with high resolution, would be with real production data on 1-second basic from all of the CPV clients at the SDP. This was not possible both because of the fact that measurement of the production only had the resolution of 6 minutes and that the CVP clients did not provided the requested data until very late in the work process. Because of the reason that Enercoutim do not own any trackers them selves, and that they just recently had installed a DNI meter, they were unable to provide any first hand data directly.

As mention earlier, the DNI data and the ambient temperature is gathered from nearby locations. The formula that was used to perform the calculations of the production is the same formula, with the same ambient temperature and static parameters, which Enercoutim uses to do their analysis of the production at the SDP. The static parameters presented in Table 4-1 are standard parameters from the Handbook of Photovoltaic Science and Engineering. The power coefficient of the CPV cells and the different losses are manufacturer data provided by the CPV clients through Enercoutim.

4.1.4.5 Real Output Data from Sonae

Actual output power measurements, from 1 MW out of the installed 4.5 MW at the SDP, were obtained towards the end of the working process. Data was received from Sonae, which is one of the clients of Enercutim, owning part of the trackers at the SDP. This real data covered all of 2015, and the resolution was 6-7 minutes between each measurements. The power outputs from every tracker's converter were aggregated and linearly scaled up, in order to get the corresponding output for the entire SDP. During this process, the 6-minutes resolution was preserved. Unfortunately, due to a non-disclosure agreement, the presentation of any of these values was not possible. Also, all the OpenModelica simulations, and thus the ES sizing, were based on the DNI-based data instead of the Sonae data since the latter was only received in the end of the master thesis period.

5 Result of Simulations Using OpenModelica

The design and dimension of the BESS are derived from the results of simulations performed in OpenModelica. The input data to the model is the power output from the SDP calculated with the measured DNI and temperature values from the south of Portugal September 2015.

The DNI varies significantly depending on the time of the day and if there are clouds passing over the platform. This cause the power output to vary and give different output profiles for different days. These varying output profiles are illustrated in Figure 5-1 and 5-2. September 17th (day 17) showed up the most varying output profile and September 19th (day 19) was the least varying day with the highest peak output.

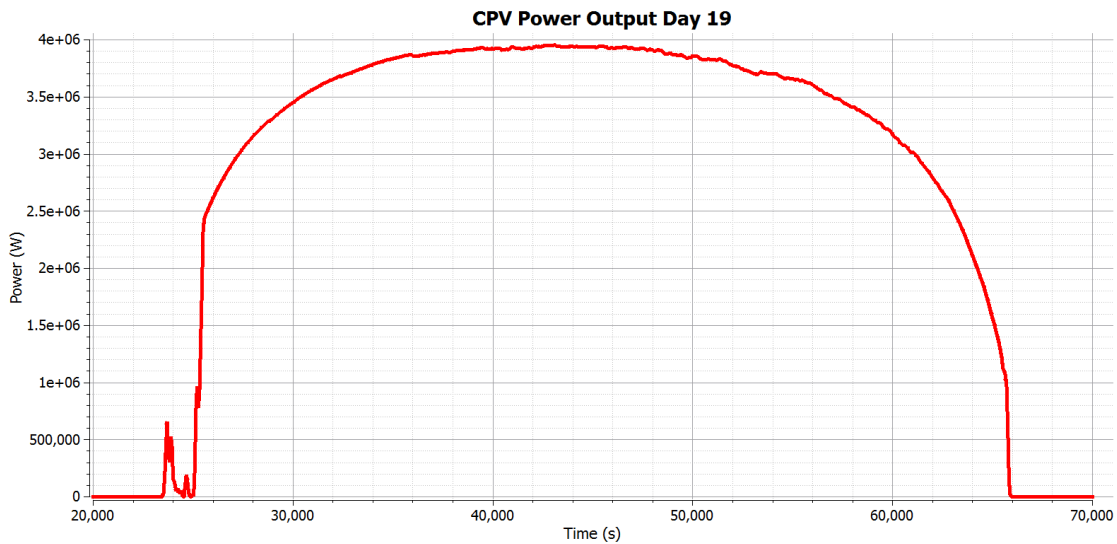

Figure 5-1. Graph describing the power output of September 19th for a close to perfect sunny day where the y-axis shows power [W] and the x-axis the time [s].

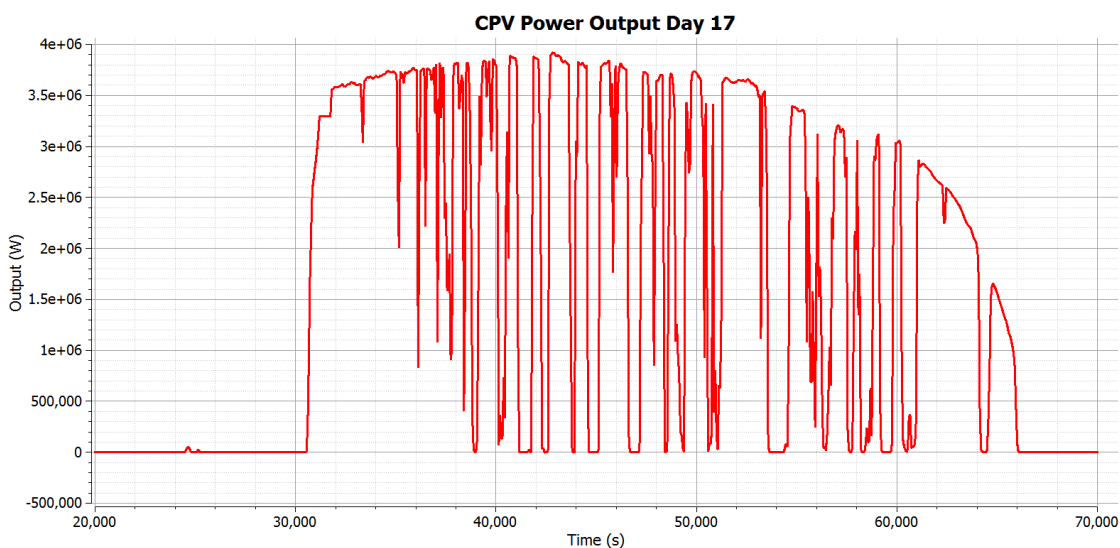

Figure 5-2. Graph describing the power output of September 17th for a sunny day with many clouds passing by during the day where the y-axis shows power [W] and the x-axis the time [s].

As seen in the two graphs, the power output profiles differ significantly. Day 17 was most likely a sunny day with many clouds, shading the sun from time to time and the day 19 was a sunny day without any clouds. Output profiles like the day 17 could cause problems to the grid and it is especially during these days that a BESS could provide several valuable services.

In this chapter the three different services will first be evaluated separately for the most extreme day according to a base case. The most extreme day for the ramping support is day 17 and for peak shaving and arbitrage it is day 19. This result will be followed by a sensitivity analysis where important parameters are changed in order to show how the new result differs from the base case. *Chapter 5.4 Design Proposal for Combined Services* will give the result when the simulations are performed with all the three services combined. This subchapter will present the final proposal of dimensions for the BESS, the LCOE and the capital cost, together with the sensitivity analysis.

5.1 Ramping Support

As described earlier, electricity produced by CPV technologies is highly varying and this could be problematic for the local distribution grid. To prevent this extreme fluctuation the simulated BESS has been designed to charge and discharge to guarantee a maximum ramp rate of power per minute to the grid.

5.1.1 Base Case

According to chapter 3.1, some countries and regions have already implemented a maximum ramp rate for power delivered to the grid produced by wind and solar power plants. The base case for ramping support is that the BESS should provide a guarantee that the power output from the SDP never fluctuates greater than 10 % of i.c./min. With an installed capacity of 4.5 MW, or 4 500 kW, the maximum ramp rate is 7.5 kW per second for the SDP (assuming a linearly scaled down power to time relation).

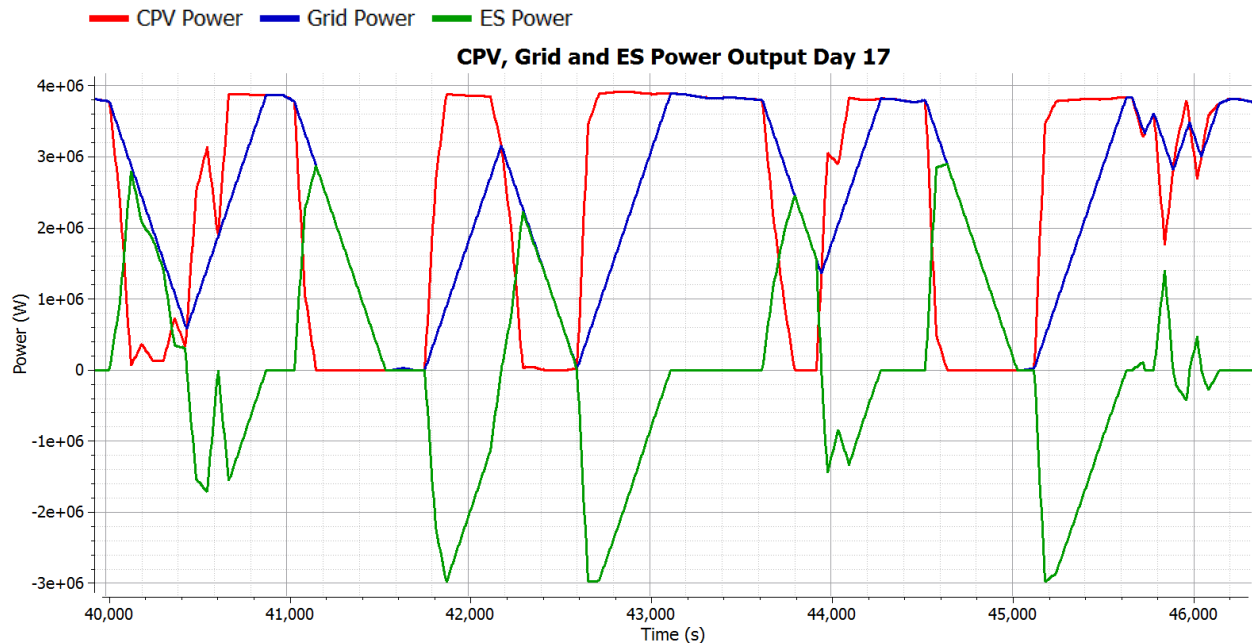

Figure 5-3. Graph describing how the BESS prevent rapid changes in power output to the grid and when the BESS is charging/discharging over a time of 6000 seconds (about 1.5h) during day 17.

Figure 5-3 shows how the power output from the BESS, the CPV and the delivered electricity to the grid would look like in the middle of day 17, if the allowed maximum ramp rate were 10 % of i.c./min. It is particularly interesting to see how the BESS smoothens out the power output to the grid. Without the BESS the delivered electricity to the grid would have the same profile as the CPV output (red line). Instead it is the blue line that illustrates the power delivered to the grid.

One of these events occurs around 42,000 seconds. At this time, the power production from the CPV (red line) has in a short time span raised from 0 to 4 MW. This ramp-rate is faster than the 10 % of i.c./min. To prevent a delivery of this huge power spike to the grid, the battery (green line) has to absorb a big amount of energy in a short time period which results in a 3 MW charging power just before the 42,000 seconds event. Due to the energy absorption by the battery, the delivered power to the grid (blue line) is exactly the 10 % of i.c./min and the short power spike from 0 to 4 MW has been lowered to a more slowly growing spike from 0 to 3 MW instead. Just after the 42,000 seconds event, the power production from the CPV decreases from 4 to 0 MW which now instead results in a power output, from the battery to the grid, to prevent a negative ramp rate that exceeds the set limits.

The BESS is working almost all the time and generally with a high power profile. Figure 5-4 illustrates how the power signal of the BESS is varying during the day and also the magnitude of the power output/input to the BESS.

The number of times the SDP exceeds the 7.5 kW/minute for the month of September is 605 times. If September would be considered as an average case in terms of fluctuating power output from the SDP, the total amount of violations against a maximum of 10 % of i.c./min would be 7260. This number could be

compared to van Haarens, whose studies conclude that a 5 MW PV plant in North America had 8700 violations for the 10 % rule.

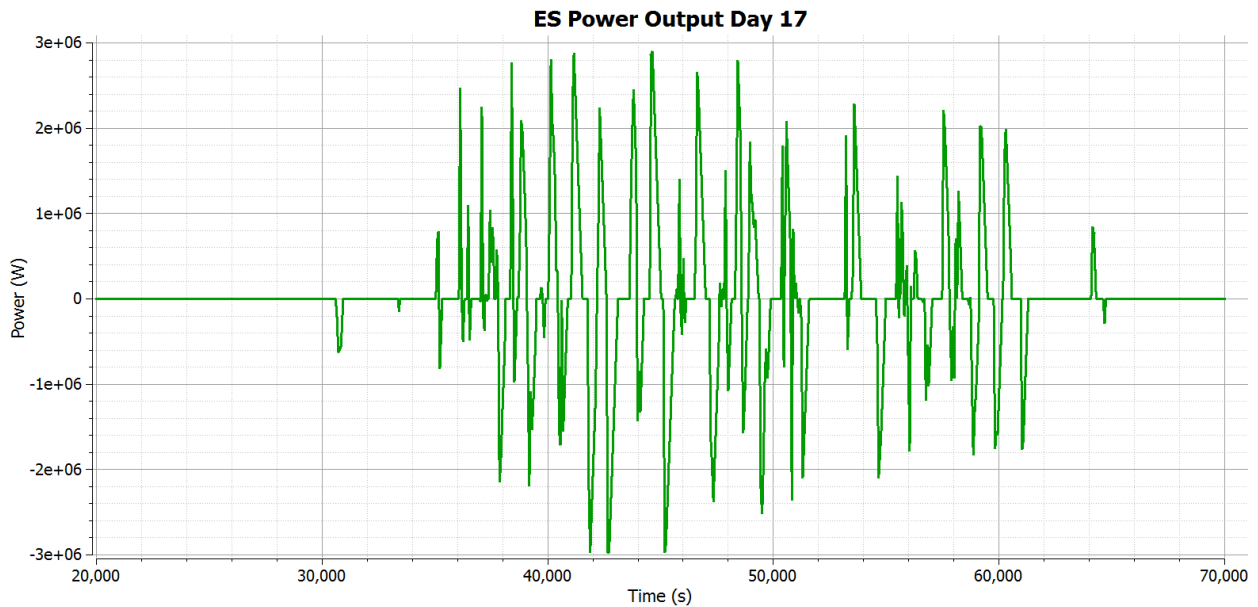

Figure 5-4. Graph showing when the battery is charging and discharging for the whole day 17. The maximum power output/input for this day is 2.97 MW.

The power profile is highly varying and the maximum power output and input is during the middle of the day when the CPV output is at maximum. The maximum power output/input of the BESS for the described base case is 2.97 MW. This is also the second highest power output recorded for the whole month of September. The highest power output was registered on September 24th with a magnitude of 3.13 MW. This means that the BESS need to be able to provide at least 3.13 MW in order to provide a maximum ramp rate of 10 % of i.c./min 100 % of the time.

The energy rating of a BESS that provide this service is low compared to the required power rating. Figure 5-5 illustrates how the energy, expressed in kWh, is varying during the same day.

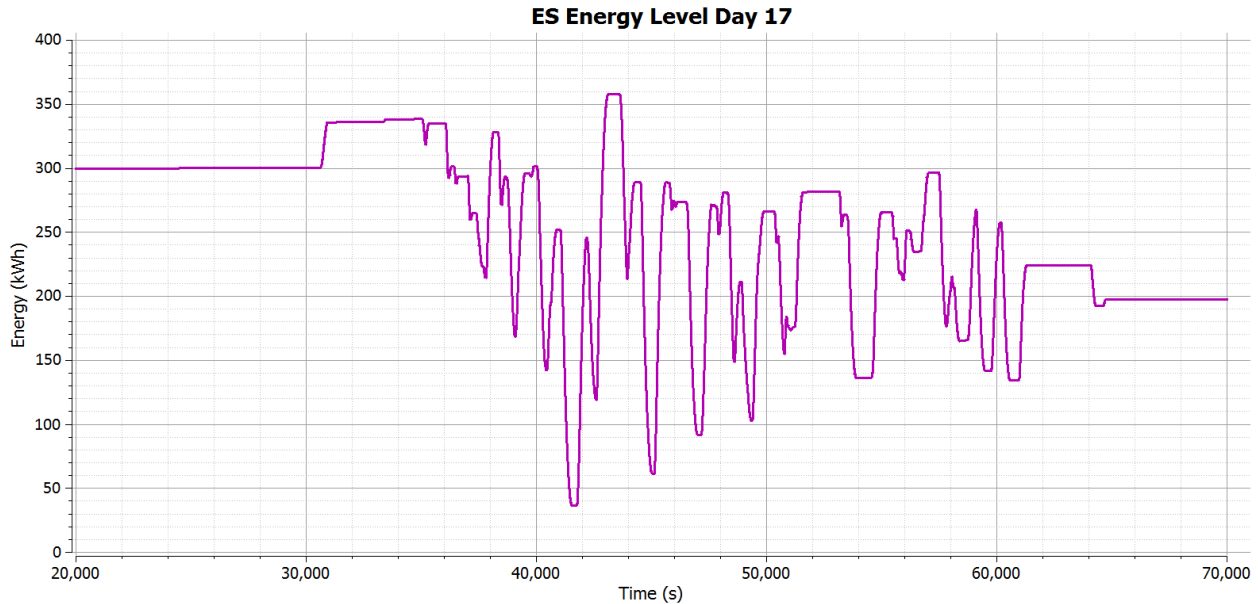

Figure 5-5. Graph that indicates how the energy content, expressed in kWh, would change during day 17. If the BESS would provide this service only this day, it would lose 102 kWh from the morning to the evening.

Because of the fact that the BESS is working to both prevent the maximum positive and negative ramp rate for shorter time periods, the BESS does not need to store large amounts of energy. The cause of the extreme ramp rates is the cloud's movement over the platform. The speed and structure of an approaching cloud is usually very similar to when the same cloud leaves from shading the platform. This is why the energy rating does not have to be very large. The energy that is used to prevent a positive ramp rate is often used to prevent a negative ramp rate soon after. The fact that the energy content is starting the day at around 300 kWh and ending the day 200 kWh lower, displays that the BESS continuously would decline in energy if every day would be like the day 17. This would suggest an overnight charging strategy if ramp rate control would be the only considered service.

The values for the energy levels during this day are minimum 36 kWh and maximum 358 kWh. This gives a maximum daily variation in energy of 322 kWh. Since in our data set, this day is the most extreme one according to continues ramp rates, the obtained energy variation will be the dimensioning case. However, it should be mentioned that this energy capacity was obtained when no output following strategy was used for keeping the ES energy levels low. This means that a lower required energy capacity could be reached if the BESS energy level would follow the CPV output, to always be optimally charged for any given ramp rate event. This control strategy was not implemented in our case, based on our suspicions that ramp rate control would not be the dimensioning service in terms of energy, for the final BESS design.

Combining the results for extreme values in Figure 5-4 and Figure 5-5 a ratio between power and energy (P:E) requirement can be obtained. For the base case of 10 % of i.c./min ramp rate the required power would be 3.13 MW and the energy capacity would be 0.322 MWh. This results in a P:E ratio of 10:1.

In the research carried out by (Haaren, R, 2014), where the ES is dimensioned for ramp rate control only, the obtained P:E ratio was 12:1. Differences compared to this outcome can be traced back to differences in location and therefore production data, plant sizes, differences in interpretation of the proposed regulation (minute or second based limits) and control strategies.

The simulated result for the base case with a required battery output of 3.13 MW and required energy content of 0.322 MWh is compared to the empirical determined equations (4.1, 4.2 and 4.3) from (Marcos J. , Storkël, Marroyo, Garcia, & Lorenzo, 2014). With a short dimension (l) of 384 meters gives a τ of 15.63 seconds. By inserting this τ , an installed capacity (P^*) of 4.5 MW and a maximum ramp rate of 10 % of i.c./min, the calculated required battery output equals 3.70 MW and the required battery energy content equals 0.49 MWh. This is in line with the simulated result when only considering ramp rate for the presented base case.

Table 5-1. Required power and energy rating for the BESS to handle the base case 100 % of time in terms of maximum ramp rate.

Power [MW]	Energy [MWh]
3.130	0.322

5.1.2 Sensitivity Analysis

To understand how a change in the maximum ramp rate would affect the dimension of the BESS, a sensitivity analysis was performed. Six different ramp rates were tested from 3.75 kW/s (5 % of i.c./min) to 22.5 kW/s (30 % of i.c./min) with an interval of 3.75 kW/s between every ramp rate. The result is presented in Figure 5-6.

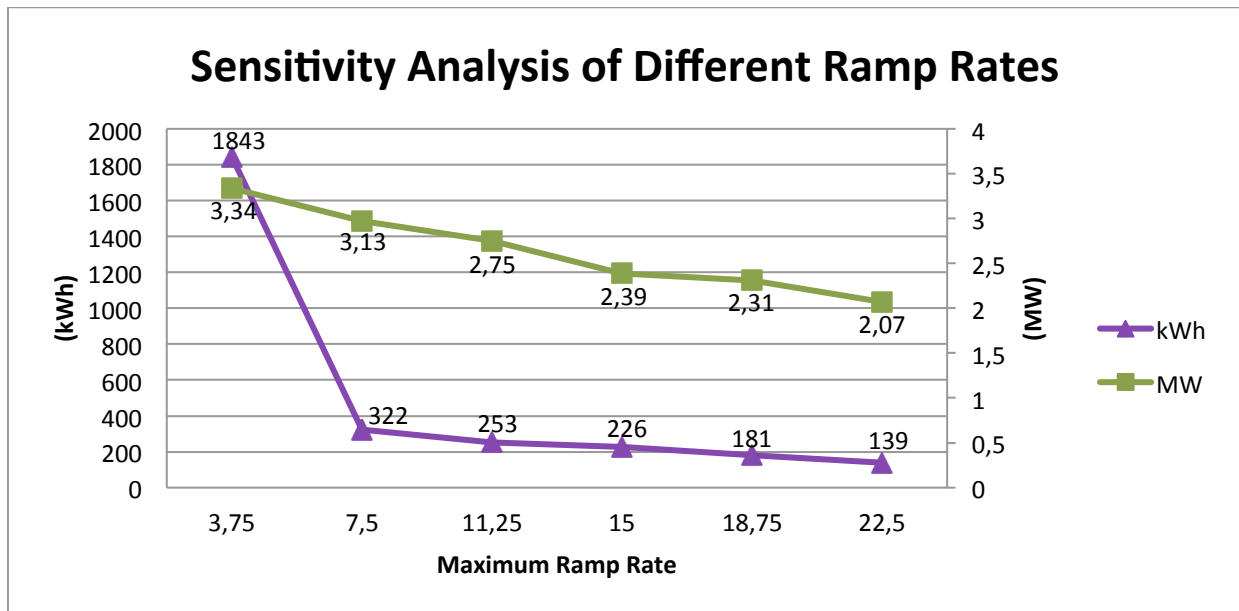

Figure 5-6. Graph showing how the dimensions of the BESS is changing depending on the ramp rate. The green line indicates the required power and is expressed at the right y-axis. The purple line indicates the required energy content and is expressed on the left y-axis.

The result of the sensitivity analysis shows that the required power for the BESS is declining in a linear way when the ramp rate is increasing. The difference in energy content between a ramp rate of 3.75 kW/s and 7.5 kW/s is much bigger than if the ramp rate is changed from 7.5 to 11.25 kW/s and upwards which is in line with van Haaren’s report. The reason why the BESS need to contain much more energy at 3.75 kW/s is due to the fact that the ramp rate is so slow that the grid power output never reach 0 MW, meaning that BESS first is absorbing energy and then releasing energy but never as much as it absorbs. This results in a constantly increase of energy in the BESS during the whole day. For the faster ramp rates the power rating of the BESS is reaching 0 MW several times per day which results in less energy. The shorter time period the BESS is working, the less energy is needed to be stored.

5.2 Peak Shaving

With plans to increase the capacity of the SDP in the future, the power output to the distribution grid could reach its maximum capacity. With the ability to “shave” the peak output, store the energy in the BESS and release it when the distribution grid is not close to its maximum capacity, the BESS can both postpone new investments and provide opportunities for a supply/demand energy market in the future.

5.2.1 Base Case

With a power output close to 4 MW_p, the base case, for peak shaving only, provides the service that the distribution grid never will receive more than 3 MW any time of the day. To provide this service, the BESS need to absorb all the energy that exceeds 3 MW during the whole day. Figure 5-7 illustrates the power output from the CPV, red line, the power the distribution grid receives, blue line, and how the power profile for the BESS is changing during a close to cloud free day September 19th 2015.

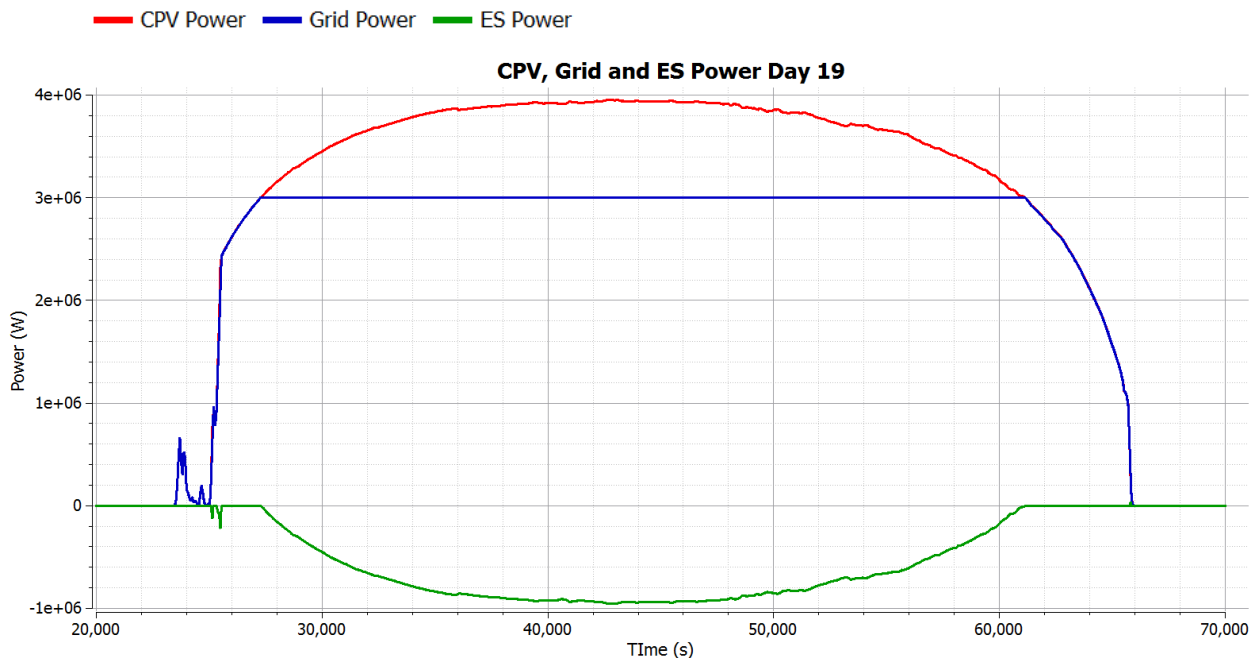

Figure 5-7. Graph demonstrating how the BESS would work if the provided service would be peak shave at 3 MW.

If the BESS only would provide the service of peak shaving this specific day, the required power is never exceeding 1 MW and the power profile is smooth most of the day.

As mention before, the BESS need to absorb all of energy that exceeds 3 MW. This results in a amount of energy that represent the area between the blue and the red line. Figure 5-8 illustrates the result of when the energy is absorbed and the magnitude of the absorbed energy for day 19.

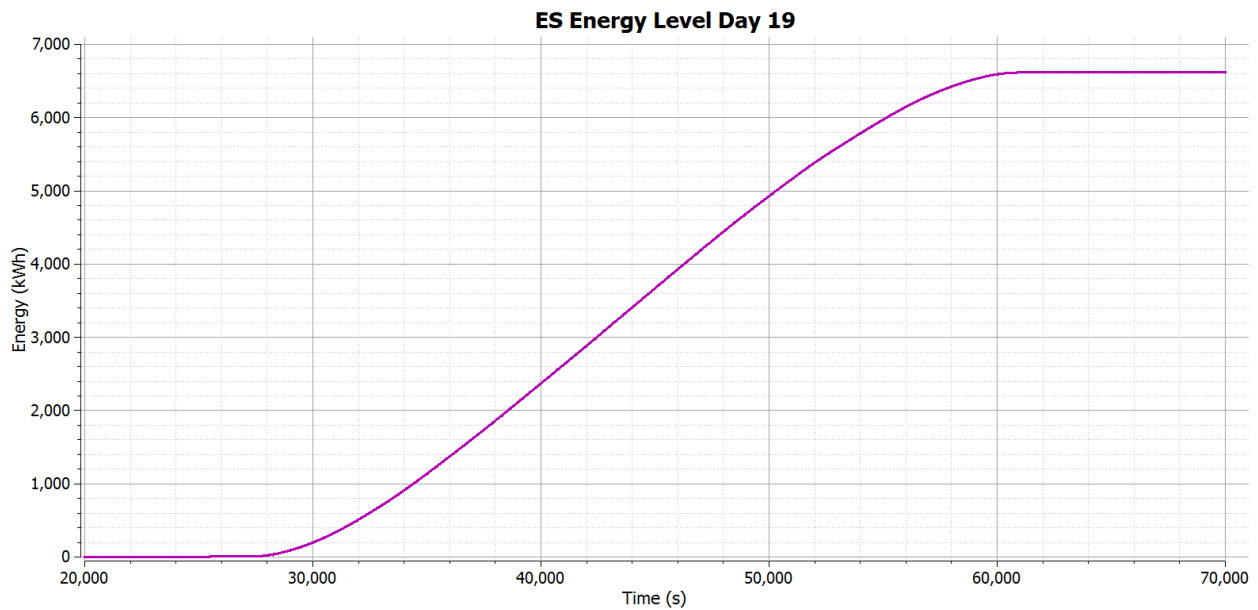

Figure 5-8. Graph shows how the energy rating in the BESS would increase for a sunny day at the SDP without any clouds if the only provided service is to peak shave at 3 MW

The amount of absorbed energy is increasing the whole day until the power output from the SDP is less than 3 MW. This results in absorption of 6.6 MWh for this specific day.

Table 5-2. Required power and energy rating for the ES to handle peak shaving for the base case.

Power [MW]	Energy [MWh]
0.95	6.60

5.2.2 Sensitivity Analysis

Depending on what maximum power output the SDP decides to deliver to the grid, the energy content of the BESS differs. In order to test the impact on the required energy content in the BESS, five different scenarios were tested. The scenarios had different levels of maximum power output to the grid, which were varying between 2.5 MW up to 3.75 MW with an interval of 0.25 MW. The result of the simulations is presented in Figure 5-9.

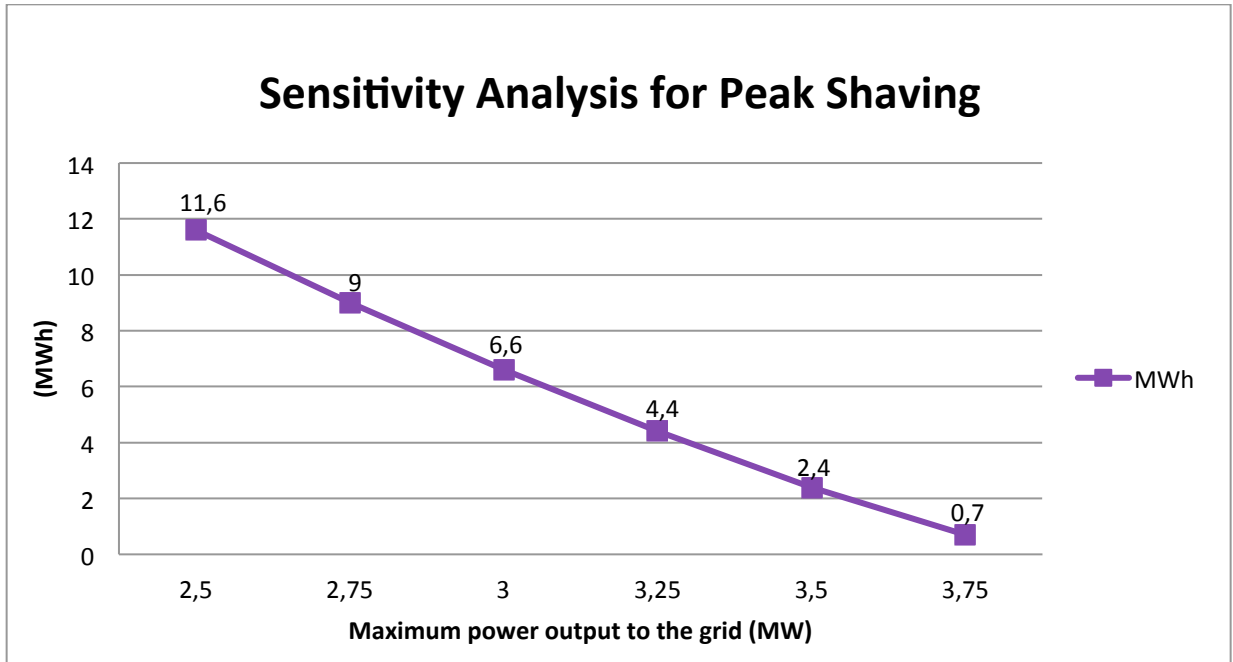

Figure 5-9. Graph showing how much energy the BESS needs to contain in order to guarantee the delivered power to the grid not to exceed a certain value. The maximum power rating to the grid was tested between 2.5 MW to 3.75 MW.

Figure 5-9 shows that the required energy rating in the BESS is directly dependent on the maximum allowed power output to the grid, when the only provided service is peak shaving. The energy rating is varying between 11.6 MWh down to 0.7 MWh with a difference of only 1.25 MW in maximum power output.

The reason why the energy rating does not have a linear profile is because the power profile of the produced electricity from the CPV is not shaped like a rectangle. Instead it is shaped with a broader base, which narrows up a bit closer to the maximum power output. This results in a larger amount of required energy for every extra power unit that needs to be absorbed.

5.3 Electric Energy Time-Shift (Arbitrage)

With decreasing feed-in tariffs in Portugal and an energy market where the buy and sell price is reflecting the supply and demand of energy, new ways of gaining revenues from BESS will arise. The results in this chapter treat a BESS that absorbs energy from the CPV power production when the spot prices on the Iberian electricity market are below a static price limit and until the storage is fully charged. The BESS then injects energy to the grid when the electricity prices on the spot market are above a static price limit and when the electricity production from the CPV are 0 MW i.e. during the late evening, the night and early mornings.

5.3.1 Base Case

When the simulations were performed with only arbitrage as the single provided service, the base case treats day 19 and a BESS with a maximum energy content of 2 MWh, without any ramp rate limit or power output limit. The price data, part of it seen in figure 5-11, is taken from the spot market the same day, where the charge price was set to below 47 EUR/MWh and the selling price was set to above 52

EUR/MWh. The BESS control strategy is set to absorb energy if the spot price is below the static charge price, and if the BESS is not fully charged. It should release energy when the spot prices are above the static selling price and the CPV output is 0 MW. Figure 5-10 illustrates how the power output from the BESS, the CPV and the delivered electricity to the grid, behaves this specific day.

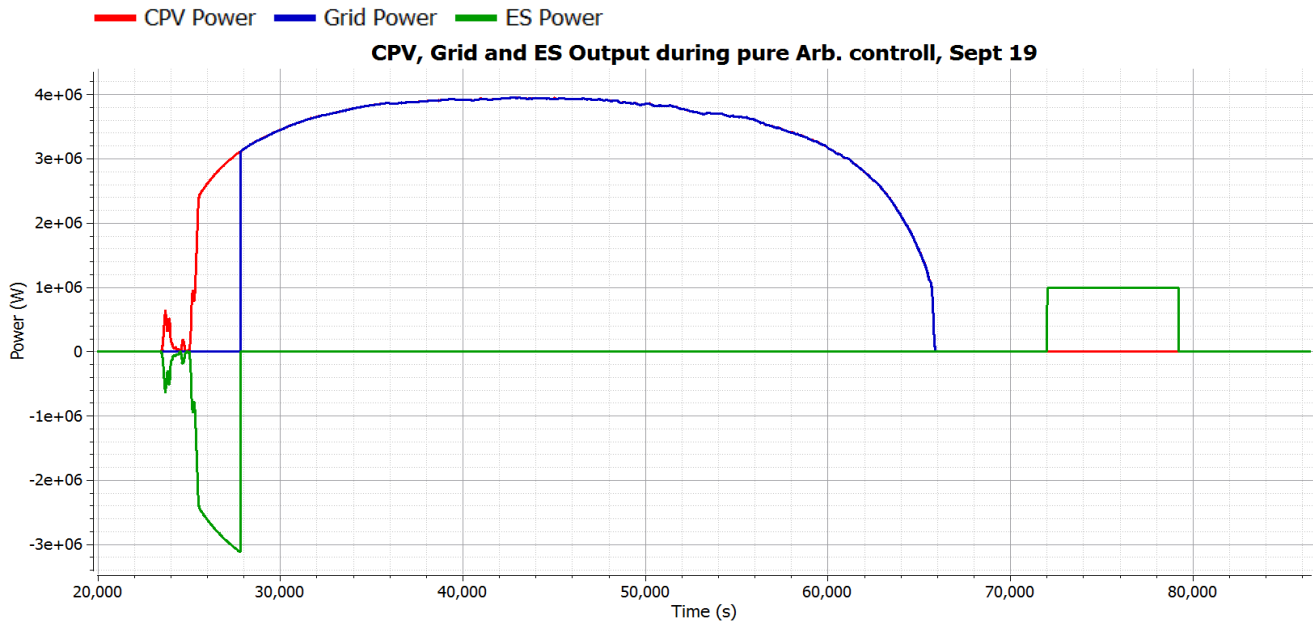

Figure 5-10. Graph that shows how the power profile of the CPV, red line, the power to the grid, blue line, and the BESS when arbitrage is the only service provided. The blue line covers the red line from about 28 000 seconds to 66 000 seconds and the green line covers the blue line from 66 000 seconds to the end of the graph.

All of the produced energy is stored in the BESS until 28 000 second into the day (around 7:45). After 7:45 all of the energy is directly injected to the grid until the CPV stops to produce any electricity in the evening. 72 000 second into the day (20:00) the BESS starts to discharge energy until 22:00 when it stops. The explanation to this result is derived from comparing Figure 5-10 with Figure 5-11. The BESS should, according to Figure 5-11, charge when the price is below 47 EUR/MWh, the dashed red line. This is the case from the start of the day until 32 400 second (09:00). The reason why the BESS stops to charge already at 07:45 is because of that the BESS is fully charged and will thereby stop to absorb more energy. The price is then rising above the selling line. This would mean that the BESS should sell energy to the grid but because of safety reasons, to not risk higher than usual constraints to the grid, the BESS is only selling energy when the price is above the selling price and when the CPV production is 0 MW. This is the reason why the delivered energy to the grid, blue line, is equal to the CPV production, red line, until 72 000 second into the day (20:00). It takes 2 hours to sell the stored 2 MWh of energy if the battery has a power output limit of 1 MW. The BESS is then empty when the next day starts.

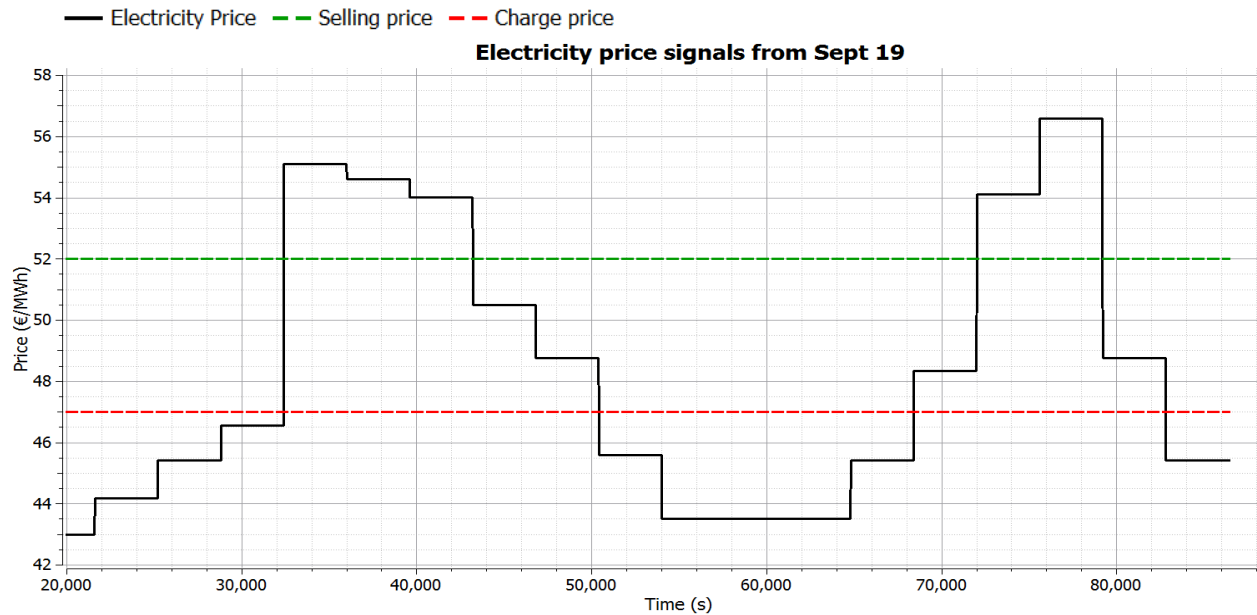

Figure 5-11. Graph showing how the hourly spot market price, expressed in EUR/MWh, is changing during day 19. The green dashed line indicates the minimum selling price and the red dashed line indicate the highest price for the BESS to charge.

5.3.2 Sensitivity analysis

A specific sensitivity analysis for the sole service of arbitrage was not carried out at this stage. The reason for this is in part, the service's low priority and in part, the lack of a real dimensioning component, when applied to our case. Instead, a sensitivity analysis for the services control strategy is carried out when it is combined with the other services in the design case, in the following subchapters.

5.4 Design Proposal for Combined Services

To design and optimize a BESS for the SDP the simulations were performed for the services of ramping support, peak shaving and arbitrage combined. This chapter gives the final result of the both the dimension of the BESS, in terms of required power and energy, and what the capital cost would apply to this BESS. Both a technical and an economical sensitivity analyse will be presented.

5.4.1 Base Case

This section will present the final result of the dimensions and costs of the BESS. The design base case is based on a maximum ramp rate of 10 % of i.c./min, peak shaving at 3.75 MW and an arbitrage service that only charge from energy gained from ramp rate and peak shaving. Ramping support is prioritized as the most important service followed by peak shaving and arbitrage as the least prioritized service.

Figure 5-12 illustrates the power output from the CPV, to the distribution grid and how the battery is working during the whole month of September. The extreme days that were simulated for testing the services one by one is day number 17 for ramping support and day number 19 for peak shaving and arbitrage.

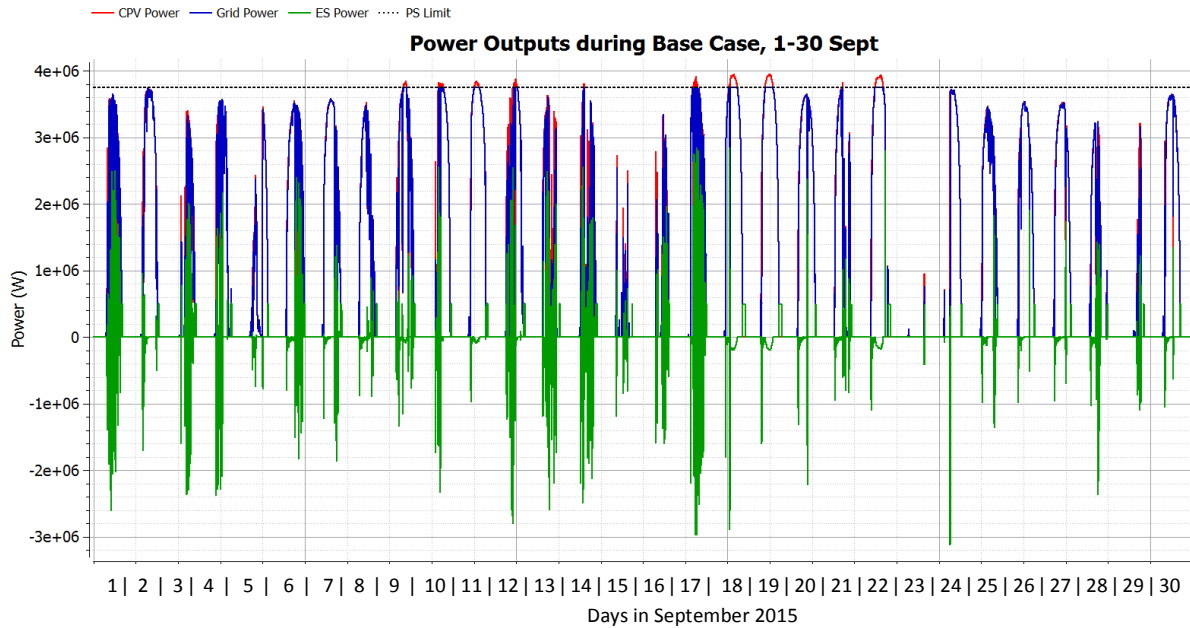

Figure 5-12. The power output [W] from the CPV, the battery and to the grid on the y-axis is plotted from the 1/9 to the 30/9.

The result shows that the highest required power for the battery is determined by one event during day 24. During day 17, a slightly lower power output was required, but for several occasions. The extreme ramp rate day 24 equals 3.3 MW per minute which is 73 % of the total plant rating. Notably is also that the power production only exceeds 3.75 MW, 10 of the 30 days which means that peak shaving at this level only is used 1/3 of the available days this month.

Figure 5-13 illustrates the required power for the battery to charge and discharge. With a peak below 0 MW means that the battery is charging and works as a load. This is the action taken to decrease the positive ramp rate or to prevent the power output for the grid to reach over 3.75 MW. When the battery instead has a power output above 0 MW that means that it is working as a generation unit and discharging energy to prevent a negative ramp rate or to sell energy through the arbitrage service.

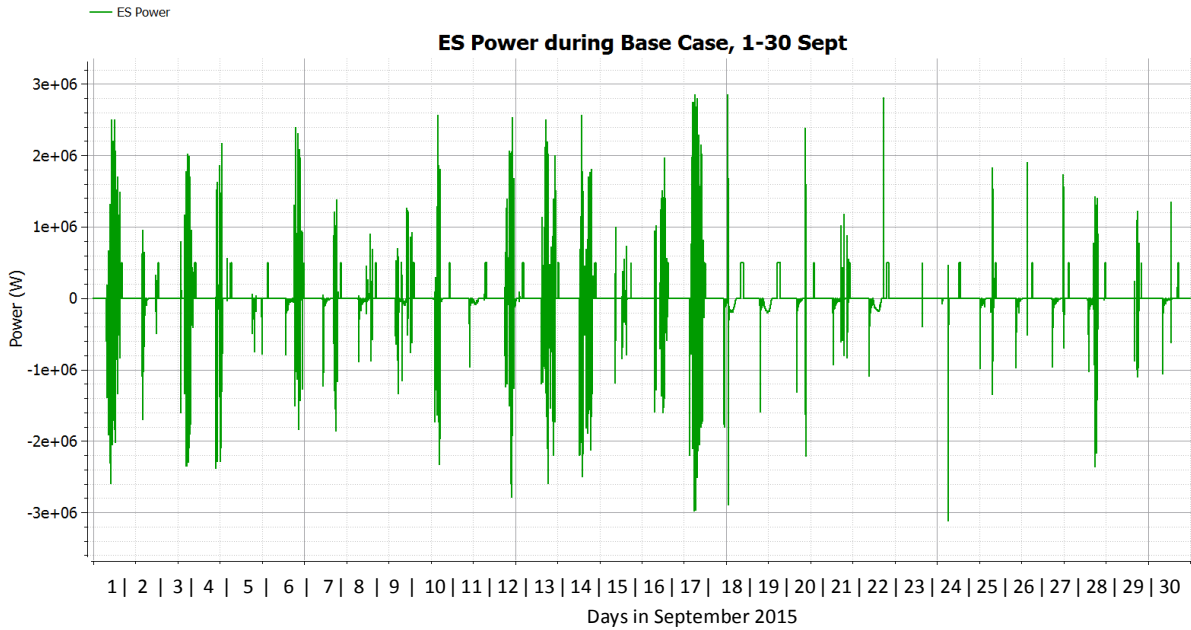

Figure 5-13. Illustration of the power rating requirement of the battery from the 1st to the 30th of September.

Figure 5-13 shows that the power only exceeds 3 MW one single time during the whole month, see day 24. It also proves that the power exceeds 2.5 MW 29 times, 2.75 MW 13 times and 2.9 MW 5 times of a total amount of 605 occurrence of a ramp rate exceeding the 10 % rule.

The required energy rating in the battery from the 1st to the 30th is illustrated by figure 5-14.

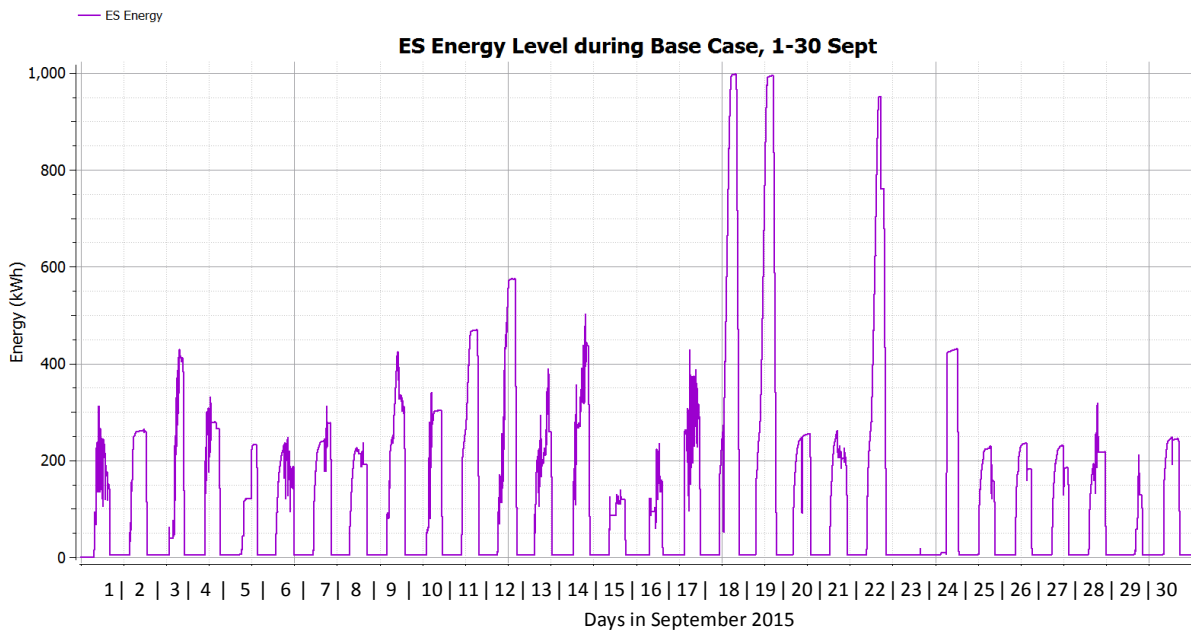

Figure 5-14. The energy content [kWh] of the battery on the y-axis is plotted from the 1/9 to the 30/9.

During day 18 and 19 are the peak notations of required energy in the battery 996 and 995 kWh. However, the majority of the days only require a battery with 500 kWh or less. Both day 18 and 19 have a high electricity production for a longer time period. The battery does not have to prevent many high ramp rates during these two days and can instead absorb all the power output that exceeds 3.75 MW. The energy profile in Figure 5-14 fits well when comparing Figure 5-12 where days 18, 19 and 22 all have a CPV power output that is above 3.75 MW for a longer time period.

5.4.2 Dimensioning

Figure 5-13 and 5-14 illustrates what the requirements for the BESS are in terms of energy and power to handle the base case in September 2015 for 100 % of the cases. The ideal scenario would be to invest in a BESS that can provide at least those dimensions but with an increasing cost for every additional watt and kWh, the most ideal scenario becomes often an expensive one.

This chapter will first present the final dimension for the BESS and then explain the chosen numbers.

Table 5-3. The proposed dimension of power and energy rating for the planned BESS at the SDP.

Power [MW]	Energy [MWh]
2.75	1.0

5.4.2.1 Power Sizing

The rated power of the BESS is chosen to be 2.75 MW. As earlier mentioned, and seen in figure 5-13, the maximum required power for the base case in the month of September is 3.13 MW. Since September is the most extreme month regarding ramp rate events in 2015, we can assume that no other month will require a higher power limit from the ES. However, for this month, a rated power at 2.75 MW would mean a power that is insufficient for 13 ramp events, out of 605 in total.

In order to keep costs low for the investment of the BESS, it can be economically beneficial to consider a lower power capacity than what would cover even the most extreme events. The reason is that the dimensions, and therefore costs, tend to grow exponentially towards the end of the spectrum, when including all possible ramp rate events. It is usually wiser to dimension a system to cover a set percentage of the cases, for example 98 %. This is the number that has been used in this report for the month of September. If 98 % of the ramp rate events have been mitigated in September (the most extreme month), chances are high that maybe 99 % per cent of cases over the whole year can be met with this rated power. However, since only data for September was available, the coverage percentage can only be calculated for this month.

Regarding the events when the rated power will not be enough, roughly half of the events will be when the BESS power is approaching the positive limit (2.75 MW) and half of the events the negative limit (-2.75 MW). This can be seen in Figure 5-13. In the cases when the battery is absorbing energy, like in the single most extreme case of -3.13 MW, the system can be designed to curtail the produced power from the CPV trackers. The result will be a slightly lower energy production, but also the avoidance of possible

penalty fees due to ramp rate violation. This means that roughly half of the events exceeding the BESS rated power can still be coped with, without resulting in penalty fees.

5.4.2.2 Energy Sizing

The energy capacity of the BESS was chosen to be 1 MWh. The reason is that the energy dimensioning services, peak shaving and arbitrage, both were classified as being of the character “bigger is better”. That is why these services, in our case, are not truly energy dimensioning. A certain threshold value is hard to find. Since no data or indications for a certain system-required peak shaving level could be obtained, it was concluded that this service will have more of a demonstration purpose in the final BESS design. The same thought applies to the arbitrage service, since the growing investment costs for a bigger energy capacity could (with today’s electricity prices) not be covered with the higher revenues from larger quantities of energy trading.

Also, it makes sense to stay in the order of magnitude of the energy capacity suggested for ramp rate control. The ramp rate control is after all the prioritized service, and in addition, the only really dimensioning service. However, with this suggested energy capacity of around 0.322 MWh, it would be hard to demonstrate the peak shaving and arbitrage services. Instead, 1 MWh was chosen to be able to shave production peaks at 3.75 MW, which is a small but distinguishable level on the CPV output diagram.

When considering other months with higher DNI values than September, it could be necessary to peak shave at a higher level, for example at 3.8 MW, during very sunny days. The peak shaving level is designed with the option to be changed at any time. This means that the system would most probably be self-adapting during the first year of operation and adapt the optimal peak shaving limit over the year.

5.4.3 Sizing Sensitivity Analysis

In order to investigate how a change in the power output from the CPV change the dimensions of the battery, a sensitivity analysis has been performed. The sensitivity analyse is testing a 10 % increase and decrease of the CPV production for the dimensioning days. The power and energy rating should be compared to the base case without optimization e.g. 3.13 MW and 0.95 MWh. No other parameters have been changed from the base case than the CPV production.

Table 5-4. Required power rating [MW] and energy rating [MWh] for a +/- 10 % increase of the CPV production and with a peak shaving limit at 3.75 MW as in the base case.

Case	Power rating (MW)	Energy rating (MWh)
+10 % CPV Output	3.54	3.63
-10 % CPV Output	2.82	0.40

As Table 5-4 presents, the power rating is increasing with 0.38 MW and decrease with 0.34 MW, which is a 12 % increase for every 10 % increase of CPV output. The energy rating is on the other hand increasing with 2.68 MWh with a 10 % increase of CPV output and decreasing with 0.55 MWh when decreasing with 10 % of the CPV production. This shows that the energy rating is very sensitive to a difference in the power output and increase exponentially compared to the power rating that increase in a more linear

way. This result is in line with the sensitivity analysis performed for the services individually simulated. However, this follows from the fact that the peak shaving limit of 3.75 MW is kept constant during the 10 % CPV variations. The peak shaving limit used in this sensitivity analysis is chosen according to the base case characteristics of CPV output for September. The shaving limits would need to be adapted according to the changing CPV output during real operation conditions.

A change of +/- 10 % of the power output can illustrate a perfect sunny day in July when the DNI is at its top notation compared to a day in December when the DNI values are lower. This difference in CPV output during a year is important to take into consideration in order to not over, or under, dimension the BESS.

5.4.4 Arbitrage Analysis

If the BESS charges when during the day mostly due to peak shaving, and sell the electricity when the price is high, additional revenues can be achieved. The key factor is to investigate how much difference in additional revenues the arbitrage service can provide with a different control strategy.

Table 5-5. Three cases of revenues with and without arbitrage are presented and compared to each other.

September	Revenue without arbitrage	Revenue with base case arbitrage	Revenue with maximized arbitrage
Total revenue [EUR]	36 704.00	36 821.80	36 997.82
Difference [EUR]	0.00	117.80	293.82
Difference [%]	0.00	0.30	0.80

The revenue for three different cases for arbitrage was calculated and is presented in Table 5-5. The numbers represent calculated revenues only for the month of September.

The column “Revenue without arbitrage” represents the control case in order to value the arbitrage service. This case is based on the system layout as it is today, without any ES. The revenue is calculated through hour-by-hour multiplication of the energy that has been injected to the grid, with the corresponding electricity price for that hour.

The column “Revenue with base case arbitrage” shows the revenues for the month, when using the 1 MWh BESS, presented in the base case. The control strategy for charging used for this case is the same as for the base case for just this service. That means that the BESS is charged only due to peak shaving (at 3.75 MW) and during ramp rate events (exceeding 10 % of i.c./min). After sunset the BESS is discharged at the highest evening price point.

The last column “Revenue with maximized arbitrage” shows the numbers for a case with an arbitrage maximizing control strategy for the BEES charging during production hours. The case is still based on the exact same BESS configuration as for the base case (1 MWh, peak shaving at 3.75 MW and ramp rate limiting at 10 % of i.c./min). The difference is the charge control strategy, which aims to keep the storage fully charged at sunset, anticipating an evening price peak. In this way, the full BESS energy capacity is used, for the most days, to maximize the revenue based on price variations.

5.4.5 Capital Cost Analysis

The capital cost analysis is performed with data from the proposed dimensions, Table 5-6, together with the presented costs per kWh and kW and equations in chapter 3.4 *Investment Environment*. All the capital costs are presented in million euros (MEUR) with the exchange rate of the 1 of June 2016.

Table 5-6. The average, minimum and highest power and energy cost for Li-ion, NaS and Lead-acid batteries.

Technology	Power cost [MEUR] (Average)	Energy cost [MEUR] (Average)	Power cost [MEUR] (High)	Energy cost [MEUR] (High)	Power cost [MEUR] (Low)	Energy cost [MEUR] (Low)
Li-ion	6.33	3.15	10.01	5.51	2.65	0.80
NaS	8.67	0.44	9.77	0.49	7.57	0.40
Lead-acid	8.24	1.84	14.16	3.37	2.32	0.31

Li-ion, NaS and Lead-acid batteries are all best in at least one of the categories. Li-ion has the lowest average power cost but by far the highest average energy cost. NaS instead has the highest average power cost but the absolute lowest energy cost. When looking at the highest and lowest power and possible energy cost it is Lead-acid that stands out in both high and low cost.

According to Table 5-6, it is clear that batteries of NaS type are most cost-effective if the energy dimension is high and the power dimension lower. The span from a low energy cost to a high energy cost for NaS batteries is very short and much bigger for both Li-ion and Lead-acid batteries. However, Lead-acid has the lowest possible energy cost. Hence, in some situations Lead-acid could be favoured before NaS batteries even if the energy cost is in focus.

Table 5-7. The total capital cost (power + energy) is presented for an average, high and low case.

Technology	Power + energy cost [MEUR](Average)	Power + energy cost [MEUR] (High)	Power + energy cost [MEUR] (Low)
Li-ion	9.48	15.52	3.45
NaS	9.11	10.26	7.97
Lead-acid	10.08	17.53	2.63

When the total capital cost for the three BESS is determined in Table 5-7, it clear that the NaS batteries, capital cost wise, is the best option for the SDP when looking at the average cost and the highest possible cost. Lead-acid is the best option if just looking on the lowest possible capital cost and Li-ion is in all three scenarios the second best alternative.

5.4.6 Technology of Choice

The simulations of the power output from the CPV in combination with an BESS has given a dimension of the storage with a power to energy ratio of about 3:1 to manage ramping support, peak shaving and arbitrage. The dimensions of the BESS have then resulted in a cost analysis of the average, lowest and highest possible cost per energy and power.

With the presented result in hand, the LCOE for each battery presented earlier and with the assumption that the average cost is the most relevant cost to consider, the choice of ES technology for the SDP is a NaS battery.

Table 5-8. The proposed technology of choice for the planned BESS at the SDP.

BESS Technology	Sodium-Sulphur (NaS)
-----------------	----------------------

5.5 ESS Expansion Options for a Growing SDP

With a forecasted future increase of installed capacity from 4.5 MW to 6 MW, and the knowledge that the DSO could experience problems at this power levels, it is interesting to investigate how much the dimensions of the battery would increase to secure a stable grid. The stable peak power level to the grid is set at 4 MW_p, mostly because that is the peak of today's system. Thus, the peak shaving limit is set at 4 MW. The ramp rate limit is the same as in the base case.

Table 5-9. Required power rating [MW] and energy rating [MWh] for a 1.5 MW increase of the installed capacity at the SDP and with a peak shaving limit at 4 MW.

Case	Power rating (MW)	Energy rating (MWh)
+50 % CPV Output (6 MW _p)	4.96	16.70

For a battery to handle this new challenge, the power rating need to be increased from 3.13 MW to 4.96 MW and the energy capacity from 1 MWh to 16.7 MWh. The last mentioned change translates to almost 17 times the size of the energy rating for the base case. Table 5-10 shows how the capital cost of power, energy and the total capital cost would change from the base case.

Table 5-10. The power cost, energy cost and the total capital cost is presented in millions EUR for the base case and the future expansion to 6 MW installed capacity.

Cases	Power cost [MEUR] (Average)	Energy cost [MEUR] (Average)	Total capital cost [MEUR] (Average)
Base case	8.67	0.44	9.11
Future, 6 MW _p	15.64	7.41	23.05
Difference	6.97	6.97	13.94

The difference in total capital cost between the base case and the future 6 MW is 13.94 MEUR, which is more than the double cost. This cost needs to be compared to the capital cost of an upgrade of the distribution grid to handle this increase of installed capacity. 23.05 MEUR is a big capital cost but what stands out in the result is the cost per the extra energy rating compared to the extra power rating. Both costs increase by 6.97 MEUR even though the energy rating has increased by a factor of nearly 17 and the power not even by a factor of 2. This result clearly shows that an increase in energy rating of a NaS battery is not as costly compared to the same increase in power rating (counting in MW and MWh respectively). The cost could dramatically be decreased if the power rating would remain accordingly to

the base case, so that only an increase of energy rating would be in place. This would mean that the NaS battery would not be able to handle a maximum ramp rate of 10 % of i.c./min but it could provide the guarantee that the power output would not exceed 4 MW to the grid. This would propose a better investment offer in order to provide the distribution upgrade deferral service, which is more dependent on peak shaving than ramping support.

6 Discussion

This chapter will first discuss and evaluate the report and uncertainties with the thesis, then followed by its limitations. The discussion is wrapped up with suggestions to what research can be followed up after this thesis in the future.

6.1 Evaluation of the Report

The aim with the method of this thesis was to provide enough basic understandings, in the areas of ESS and simulations, to understand why a NaS battery with the specified dimensions was proposed for the SDP.

The ESS environment is a relative new area with a fast pace of progression. With a very thorough literature review in the area of regulations, technologies, services, economy and case studies, both for today and for the future, a reliable basis was founded to start the simulations. Already existing studies in the area of BESS in combination with intermittent power production were chosen to provide the simulations with key parameters, for comparing results and verifying our method. The final result was then presented for every service isolated, then in combination and finally different sensitivity analyses were performed to understand the impact of changing parameters.

With the purpose to provide Enercutim with a decision basis of the most appropriate and optimized ESS for the SDP, for present day and for the future, the choice of method has worked well. According to (Akhil, et al., 2015) the method to design an ESS is always to ask the question *“is the grid operational or planning problem defined?”* If the answer is “yes” then the next question should be *“can ES help?”* If the answer is “yes” then a study should be performed but if the answer is “no” then you should stop (Akhil, et al., 2015). In this case the grid operational and planning problems were not defined which forced us to start the thesis with a broader perspective than else would have been needed. This approach is more time consuming but it also provides benefits of a better understanding of the area of energy storage. This approach also forced us to apply a new perspective, when first of all we had to try to find problems to be solved.

Aiming to answer questions concerning dimensions and economic interests for services provided by an ESS, both for Enercutim and for the DSO, resulted up in a capital cost analysis depending on the power and energy rating and a LCOE analyse to compare the three batteries. The two different ways to calculate costs provide a valid estimation of how much a BESS of a certain dimension would cost, but did not revile the economic interests in the way we had hoped for. In order to provide a good estimation on the true values of the proposed services, today and in the future, the master thesis should only have aimed for this question and compared economical parameters with the regulatory environment and how it might change. Because of time constrains and with the primary aim to perform simulations to optimize an ESS for the SDP, this is only discussed and roughly calculated with help of the LCOE.

The way to present the result in five different base scenarios, first with focus one service, then combined and last a future scenario, with sensitivity analysis, is an explanatory way to understand the complex problem. In this way it could be identified why a certain parameter can be more important than others.

Illustrative graphs were derived from OpenModelica to complement the presented numbers in the tables to further make the result easier to understand.

6.1.1 Choice of Technology

Early in the filtering process it has been clear that Li-ion, NaS and Lead-acid batteries has been the three considered ES technologies for the SDP. A NaS battery was chosen as the best-suited battery in the end but a Li-ion or a Lead-acid could also be valid options. The main reasons why NaS was chosen before the other batteries was because of the lowest LCOE, the lowest average total capital cost and the fact that NaS has a significant lower capital cost per kWh. The reasons why we have valued the capital cost of energy higher than the capital cost of power is because of two factors. The first one is that the installed capacity at the SDP will be increased which might require a higher energy rating for a BESS to prevent upgrades in the distribution grid. The second reason is that a maximum ramp rate at 10 % of i.c./min is a tough regulation and also that we even have dimension the BESS to guarantee this service every second and not only per minute. This means that a BESS that is dimensioned for 2.75 MW is likely to perform well even for increased power production levels. This is discussed more carefully later. The fact that the power to energy ratio is about 3 to 1 and that NaS despite this is the cheapest choice further strengthens the choice of battery. The main argument against a NaS battery is the low RTE (lowest of the three batteries) and the fact that NaS batteries ideal should only go down to 10 % of SoC. This speaks against the use of NaS especially for arbitrage where it would be preferred to sell all the energy during the night. To include a control system that only allows the arbitrage service to discharge down to 10 % of full capacity would be advised.

In the end of the result it was clear that it was either a Li-ion or NaS battery that was the best choice and not Lead-acid. The reasons why Lead-acid was disregarded was mainly because of the very high capital cost intervals and the fact that a Lead-acid battery prefers to have a high SoC. This value should never exceed 20 % (and preferably more) to guarantee an acceptable expected lifetime. This is also showed with the expected lifetime interval that ranges from 3 years to 15 years. With the two services, peak shaving and arbitrage, the aim is to first have space in the battery to handle a peak shaving for a full clear day and later to sell most of the energy during the evening. This leads to at least one very deep discharge of the battery per day, which would not be ideal for a Lead-acid battery. Lead-acid would be a better choice if ramping support would be the prioritized considered service.

To have a Li-ion battery instead of a NaS battery would be possible. The main advantages for Li-ion batteries over NaS are the higher RTE, the lower capital cost per kW and the economic forecast that foretells a drastic cost reduction in the close future. The main disadvantages are the very high LCOE today and the high capital cost per kWh. Li-ion batteries would be the best battery but with a LCOE that is over two times higher than NaS it is hard to argue for a Li-ion over a NaS battery. If the BESS is to be installed in a couple of years, and the cost reduction of Li-ion batteries follows the predictions, the situation could be in favour for Li-ion instead.

The thesis has given examples of how all of these batteries can be used for similar services as ramping support, peak shaving and arbitrage. (Nykamp, Molderink, Hurink, & Smit, 2013) proposed that Li-ion batteries was the best suited for peak shaving but (Subburaj, Pushpakaran, Bayne, 2015) on the other

hand concluded that Lead-acid batteries today generally is the best choice for ESS. Also, NaS, Ni-Fe and that redox flow batteries were mentioned to be viable options with low LCOE and long lifetime. Li-ion was in that report concluded to be interesting for the future but too costly today. In addition to this, a type of NaS battery was chosen in Italy to provide different ancillary services for a small CPV plant. This further shows that there is no universal battery that always is better than the others. Instead it is a fast changing market where every case needs to be carefully evaluated to find the best suitable solution.

6.1.2 From Single Service One Day to a Full Month Combined Service Simulations

The simulations has been performed according to the method which declared that ramping support, peak shaving and arbitrage first will be analysed by themselves, for the most extreme day respectively, and thereafter the combination of services for a full month will be simulated. This method was chosen because of the importance to see what each service require from a BESS. When the services then were combined for a full month, it was easier to customise an optimal BESS that would provide each service but not be over dimensioned.

Results acquired from simulations on only ramping support showed that the required power rating of a battery was the most important parameter and that the required energy was smaller (high power to energy ratio). For the cases of peak shaving and arbitrage it was on the opposite. Here, that the energy rating was the important factor. With sensitivity analysis for all the three services isolated it is easier to evaluate how the key parameters are determine the dimension of the ESS.

6.1.3 Regulatory Ramp Rate Limit Interpretation

In this report, the suggested regulatory ramp rate limits, has been interpreted by the authors. This means that the found ramp rates, which are limited minute by minute, are by us scaled straight down to seconds. For the simulations, and thus the results, this translates to the strictest possible interpretation of the suggested ramp rate. In other words, a control that takes place every second, is more demanding than a control that takes place every 10 seconds, or with minute long power limits, like in the case of (Haaren, R, 2014) used. Our approach suggests that even if future possible ramp rate regulation turns out to be relatively strict, this should be covered by our model.

6.1.4 Adjusted Peak Shaving Level During Higher Output Months

The demonstrated peak shaving limit of 3.75 MW was chosen based on the day with the greatest total production in the month of September. Based on the design case with a 1 MWh BESS energy capacity, a continuous adjustment of the peak shaving limit could be needed, at least for the first year of operation. Since the total power output during one day should be higher e.g. in July than in September, the peak shaving limit would probably have to be increased (e.g. 3.80 MW or 3.85 MW) in order to cumulatively peak shave up to 1 MWh. The peak shaving level is thought to be easily changeable in the final BESS, since this only represents a threshold number set by the operator. As a suggestion, the control strategy for the best peak shaving limit could, after the first year of calibration, follow a seasonal record of maximum possible daily production. In addition, this control algorithm could be self adapting over the entire time of operation. However, in case the ES energy level would reach its maximum during production hours, the peak shaving service would have to be abandoned with the result of outputting the entire production directly onto the grid. With today's size of the SDP, this case should still not be a

real problem for the power export lines from the platform. However, if a problem was to be encountered for these power levels, still the temporary curtailment of CPV output remains to be an option.

6.1.5 Arbitrage Revenue

The results of the arbitrage service revenue, with a BESS energy rating of 1 MWh, show that the revenue gains of this service in the month of September are rather small. This reflects the fact that the energy storage capacity constitutes only a small fraction of the total daily energy output of the SDP. During the assessed month, the average daily energy output was 22.2 MWh. This means that the ES energy capacity equals to 4.5 % of the daily production. Thus, only this limited fraction of energy could be potentially “moved” to the ultimate price point. Furthermore, the largest positive deviation from the average electricity price in September was 32 %.

Another comment is that the arbitrage service is the least prioritized one of the three services. The suggested BESS power and energy dimensions are thus chosen with a bigger focus on the service of ramping support, and a more demonstrational purpose of the peak shaving and arbitrage service.

When considering the rather small revenue gains from the arbitrage service, based on a 1 MWh BESS, an interesting question how the arbitrage service would affect the lifetime of the ES. Possible is that with the increased deep discharges that occurs controlling for arbitrage, this could potentially affect the lifetime of the system, depending on chosen technology. This is even more the case for the arbitrage maximizing control strategy. If the BESS instead would only be controlled for ramping support, remaining at 1 MWh capacity, the full evening discharge would not be necessary every day. Hence, a possibly lifetime extending control strategy would be to only discharge the battery when it approaches its upper energy limit.

Comparing the base case of combined service with already built BESS projects that are partially or mainly focusing on arbitrage, the suggested energy capacity of 1 MWh is considerably smaller than the average for these projects. The referenced projects’ energy sizing is at least 4 times bigger for all cases except one. This fact reflects once again, that the design case for report’s ES is not optimized for the arbitrage service. The built BESS projects can be found in the report’s case study section.

When comparing with different BESS designed for arbitrage, the simulated ES is not controlled to charge during the lowest price point. Since the simulations are based on the base case including three services, it is controlled to only charge due to ramping support and peak shaving. These charging events could occur during high price points.

Probable is that the arbitrage revenue would not even increase much with a significantly bigger energy storage capacity, assuming the same type of control strategy for charging. As shown in the sizing sensitivity analysis, if the peak shaving limit was set to 3 MW, an energy capacity of 6.6 MWh would be needed. The most energy would be shaved during the hours around the mid-day. Looking at the electricity price variations of 2015, most of the days tend to show two price peaks, one smoother “peak” around noon and one sharper peak, probably before and around dinnertime. For the most part, the evening price peak is very similar or just slightly higher than the peak around noon. This means that peak

shaved energy is just “moved” from one price peak to a very similar price in the evening. The high noon energy price is especially prevalent during the summer months, where the CPV output peak coincides very nicely with the higher energy consumption due to air conditioning anyway. Also, since the evening price peak is sharper (time for the peak is usually 1-3 hours), the discharge has to be carried out at rather high output power levels.

Price signals are shown to differ a lot more when comparing night to early morning hours with the noon or evening peaks. For an ES with a big energy capacity, it would probably make more sense to buy cheap energy from the grid during the night and to sell it in the morning to noon hours. However, this control strategy would require further assessments, which falls outside the scope of this report.

A limitation of the analysis of the arbitrage service is that only output data and price data for one month out of one year has been used. It would be interesting to perform the revenue comparison over a whole year, taking into account the seasonal variations of both the power output and the electricity price. Moreover, a study for different years of power production and pricing would be valuable. Even if this would have been done, it is worth noticing that no historical data can predict what will happen to, for example energy pricing in the future.

Besides assessing longer time scales for the service, it would be valuable to run the simulations with modified price data. The price signals could be increased with different factors or the variations between the prices could be exaggerated, in order to evaluate what changes would be needed to reach a desired change in revenue. However, this exercise was not possible due to time constraints.

The method of revenue calculation for the both cases using arbitrage is probably presenting an upper limit of what could be reached with these control strategies. The reason is that the charge and discharge limits (or in other words, the price related timing of these events) were chosen retroactively and therefore at an optimal price point. This cannot be done during real time operation of the system. Some kind of advanced price forecasting strategy would probably be needed to reach the results presented for the arbitrage service.

One uncertainty of assuming arbitrage, as a possible service provided by the BESS, is that regulation for this kind of market participation is not yet set for either Portugal or within the EU. An uncertainty could also arise around the used price data and its applicability onto the compensation received by the actual power producer. The used price is the price of electricity averaged over the Portuguese market. The impacts of any tax, fees or special rates have been discarded.

One very important factor that need to be taken into consideration when determine if arbitrage would provide any additional revenues is the RTE. With a NaS battery which has its RTE in the range between 70-85 %, between 15-25 % of the charged energy is lost. With the low additional revenues that were calculated in the sensitivity analyse of arbitrage, the 15-25 % energy losses will “eat up” the extra income and arbitrage will, in our base case, not provide any extra revenues at all. The electric energy time-shift(arbitrage) service is still needed to make sure that the battery is empty, or close to empty, when the a new day starts. Better control strategies for arbitrage could make the service valuable.

6.1.6 Arbitrage Discharge Control

During the simulation of the base case for September, an arbitrage discharge rate of 0.5 MW was chosen. This discharge is taking place during evening hours after sunset every day. The real price data for the whole month was not used in this case. However, an interesting observation is that for most of the days of 2015, evening price peaks of at least two hours were identified. This would suggest that an arbitrage discharge rate of 0.5 MW would be enough to fully discharge the BESS during most evening price peak.

The used OpenModelica model would require a more complex control strategy for discharge according to varying price signals over the entire month. It would need the possibility to adapt to every days individual price profile. A possible way of control would be to simply discharge the battery according to the previous day's price signals. If the prices however would turn out to be considerably lower the current night, the BESS could be set to discharge anyway, in order to be empty for the morning peak. This type of control could certainly be implemented, but for the scope of this thesis it was delimited. The principle of nighttime discharge was successfully demonstrated with the existing model.

As discussed briefly earlier, regardless if an advanced or a basic discharge strategy is used, the BESS should be fully discharged during the night. An option could be to retain the energy level at 10 or 20 %, to avoid the deepest of discharge events. Literature suggests that for the Li-ion technology, full discharges should have rather small impacts of expected lifetime. However, for NaS it is suggested that the SoC should not fall below 10 %. For Lead-acid batteries the corresponding number is 20 %.

6.1.7 Control Strategy for Minimum Output

One possible evolution of the peak shaving service could be to implement a minimum output level, i.e. the opposite to peak shaving. During times when the BESS lie above the energy level needed for the worst ramping case, it could be set to discharge at a low but predictable level. Above all, this would lead to two apparent advantages; 1) a lower variation of the output power experienced by the external grid, and 2) some level of predictability regarding the output from the SDP. The lower grid power variations could actualize for example through peak shaving at 3.5 MW and at the same time guaranteeing an output of minimum 0.5 MW during cloud coverage. This could be maintained throughout the entire time of daylight hours as long as the period of CPV production above 3.5 MW is longer than the shaded period, and after energy for possible ramping events is accounted for. If the lower energy limit of the BESS would be reached, the minimum output would have to be aborted and ramped down in a controlled way. The fact that some level of predictability is added to the intermittent production unit could potentially translate into economic revenue for the power producer, in terms of bidding on e.g. an hour ahead market. Moreover, this could contribute to the stability of the bigger energy system.

6.1.8 DNI-Based Output Data Variations Compared to CPV Output

The data used to calculate the entire CPV Output for the SDP is based on data from one DNI meter located in Évora. The data resolution is one-minute averages. The true correspondence between the DNI based Output and the true SDP output will be discussed later but a big source of error could be the level of agreement between the actual fluctuation speeds, i.e. output ramp rates from the SDP, compared to the DNI based numbers.

Optimally, data resolution of 1-second real CPV plant output would be used. In lack of that, DNI average levels on minute resolution were used. Firstly, the sub-optimal resolution on the 1-minute level would be unable to detect intra minute variations. Secondly, there is a drawback of using DNI measurement from only one metering point, when trying to describe the output profile for an entire plant. When using the measurement from one single point, the natural ramp rate smoothing effect of any CPV (or PV) plant's geographical dispersion is lost. The geographical dispersion is due to the fact that a cloud would gradually shade the solar production plant over time. This leads to a ramp down in production, rather than an immediate drop, which could be the case for a single point measurement. This analysis suggests that the data points used for the simulations probably represents more of a worst case in ramp rates. In reality the ramp rates could be less extreme. However, this would be true only as long as no serious intra-minute variations were lost due to the sub-optimal data resolution.

To investigate if total plant output could radically drop during a one-minute time interval, literature in the area was found and consulted. Unfortunately, the results from the found research diverged, making it hard to draw any final conclusions on this point. In a research carried out in 2012 by (Marcos J. , Storkël, Marroyo, Garcia, & Lorenzo, 2014), maximum power fluctuations from different sized PV plants were presented. Relevant plant sizes of 2.64 MW_p and 9.5 MW_p were shown to result in 83 % and 70 % maximum power fluctuations per minute respectively (Marcos J. , Storkël, Marroyo, Garcia, & Lorenzo, 2014). The results propose that a sample interval of 1 minute would probably not constitute any major data gaps in the power output variation. However, it has to be mentioned that the cited fluctuation results stem from commercial PV plants, and not CPV plants. Due to the nature of the CPV technology, it is probable that high power fluctuations are reached faster than when compared to PV (as discussed earlier). Still, how much faster these variations can occur in CPV plants is unknown at this point.

6.1.9 DNI-Based Output Data Generally Compared to Real Output Data

By plotting the calculated output based on Évora DNI values together with the real tracker output, the legitimacy of the first-named could be confirmed. Through the comparison, it could be concluded that the DNI based outputs matched well with the real tracker outputs. Peaks were found to be shifted in time for some of the days, probably because of cloud patterns moving the distance between the two locations. However, no standing difference in values or shift in time could be identified.

The biggest difference between the data sets posed to be almost a full average day of real production, which was shown as near-zero values in the DNI data. However, this day was not a dimensioning day. During a clear day of production, the biggest peak differences were found to be 0.39 MW in favour the DNI data and almost 0.20 MW for the Sonae data respectively. None of these maximum differences coincided with any of the originally dimensioning days. Though, it should be mentioned that a new maximum production peak was identified somewhat higher than the original DNI-based one.

Regarding the ramp rates, naturally, the DNI data always represented higher ramp rates. This was expected due to the longer measuring intervals for the Sonae data. Hence, any conclusions regarding the real ramp rates versus the DNI-based ramp rates are hard to make with low resolution data.

6.1.10 Additional Services the BESS Could Provide

In chapter 3.3 the three services ramping support, peak shaving and arbitrage was filtered out in order to perform simulation on and dimension the BESS after but it was also stated that it is important to apply “stacking of services” e.g. design a BESS to provide as many valuable services as possible to maximize the revenues. The reason why only three services were chosen does not mean that the BESS only can provide these services but rather that there were no available data to perform other simulations on. In fact a NaS battery with these dimensions could provide many additional services within different umbrella groups of services.

The distribution services voltage support (reactive power), distribution upgrade deferral and the ancillary services of voltage support, black start, frequency response and load following are concrete examples of services that this NaS battery could provide without changing the dimensions or the design much.

As stated in chapter 3.3.1.2, the most efficient way to manage reactive power in the grid, and thereby managing the voltage, is to provide it close to the source. A DESS like this battery can provide reactive power, which would be a more efficient way than to let traditional generation units provide reactive power and then transport it to the distribution grid. Peak shaving can also give opportunity to provide the service of distribution upgrade deferral because of the ability to absorb all the power that exceeds a certain limit. This means that the battery can shave the power peaks in the grid and thereby keep the power below a critical level and thereby deferral investment in new electrical components and lines. This service is highly location dependent but has the potential to be a valuable service. When taking the current situation for the SDP into consideration, e.g. an intermittent power source far out in the distribution grid, it is likely that this service can be valuable if Enercutim and the DSO can work together.

Ancillary services can also provide new opportunities for additional revenues. Black start is a service that a battery can provide without adding additional dimension or components. The services frequency response and voltage support could also be provided to the DSO because the battery can both respond within a second of voltage and frequency abnormalities and it already has the ability to smooth out the power output by guarantee a maximum ramp rate limit of 10 % of i.c./min. These services have the opportunity to be valuable if the DSO would pay for this service or if a regulation market would be introduced in Portugal as is already the case in parts of the USA. The service load following is normally paired together with ramping support for RE because the requirements of the battery is determined by the size of the load and the intermittent power generation but the control strategy is similar. In this case, load following was neglected by the fact that the power generation was in focus but this does not mean that the battery cannot be used to load following too. This service can be valuable if the local village Martim Longo experience electrical shortage when the peak load is high and could thereby replace possible stand by generation units.

As discussed, there are many opportunities for the NaS battery to stack additional services for increased revenues. In most of the cases it is necessary to perform new simulations to get the optimal dimensions but according to the summary of requirement for different services, chapter 3.3.2, and the case study, chapter 3.5, these services are in the range of a battery with the proposed dimensions and there exist

cases where several of these services are provided together with a BESS with similar properties. The barrier to include the proposed services is generally the regulatory environment. Storages like the proposed can already today provide valuable services in terms of functionality of the grid and introduction of additional RE. The problem is that they are not valuable in terms of increased revenues, which in turn inhibits investment in ESS that provides these services. If new markets will emerge that value e.g. voltage support through ramping support, the true value of an ESS will come of its own.

6.1.11 Economy

To determine how the BESSs differ in terms of economical key numbers, the total capital cost and the LCOE has been calculated. An ideal scenario would be to present a net present value (NPV) where both the costs and the revenues are compared between the batteries. These calculations were not performed because of the fact that the revenues for the different batteries would contain too many uncertainties and thereby could give a result that is more of a guess than a realistic indication. In order to calculate the revenues of the batteries for the SDP, it is of great importance to be able to make valid assumptions of how much a specific service is worth. As presented in Figure 3-9 there is no consensus about how much a specific service is worth and the value is highly dependent on the location in terms of regulations, current bottlenecks in the distribution grid and future growth of installed production capacity. The investigation of the value of different services for a battery at the SDP has not been in the scope of this thesis, but might be interesting to study in the future.

Instead of calculating a NPV, this thesis presents the total capital cost to compare how much capital is needed to install the BESS ready to be used for the three services. The LCOE indicates how much every kWh would cost to charge, then store and later discharge, counted over the lifetime of the BESS. To provide an economic analysis that compares the average capital cost with the average LCOE provides a fair estimation of cost and value for the BESSs that could be used as a decision basis for the investment.

Table 3-6 showed that the NaS batteries have the absolute lowest LCOE (0.20 EUR/kWh) followed by Lead-acid (0.39 EUR/kWh) and last Li-ion (0.48 EUR/kWh). As stated earlier, LCOE is often used to determine which technology to invest in, and with NaS's lower LCOE than the other batteries, we can strengthen our choice of technology. The result also showed that NaS had the lowest average capital cost with this dimension even when the required power was superior to the required energy. The dimensioning was mainly focusing on ramping support where the needed power to energy ratio is high. Both peak shaving and arbitrage favour a battery with high energy content. A NaS battery would be an even better choice if the power to energy ratio would weight over in favour of the energy component. This could happen if the power output would need to be shaved at a lower level or if additional CPV production would be installed at the SDP.

As discussed briefly in choice of technology, both the capital cost and LCOE of all BESSs are believed to fall in the close future but many sources predict that the cost of Li-ion batteries would fall even faster than for other batteries. This is partly because of the highly prioritised research of these batteries to electrify the vehicle fleet. With the assumption that the proposed battery will not be installed this year or the next but instead in a couple of years, both the LCOE and the capital cost of Li-ion batteries might have been reduced to a level where they always are economic favoured over both NaS and Lead-acid. This

thesis has taken this into consideration but we believe that that the LCOE for Li-ion battery wont decrease with the required speed to reach a level below the LCOE for NaS batteries the next couple of years.

6.2 Uncertainties and Limitations

6.2.1 Changes in Regulations

As was explained in chapter 3.1, Regulatory environment, there is no consensus about how the regulations for ESS will develop and if each country should proclaim their own regulations of if e.g. the European Union should work together for trans-boundary regulations. This thesis has assumed that a ramp-rate limit will be implied, that the feed-in tariffs will be too low when the new tariff prices will be negotiated, and that an ESS will be able to participate in an hourly supply/demand market in the future. Some of these assumptions might not be relevant at the time when a possible ESS is implemented at the SDP. There is also a chance that future regulations will have open up, or closed, the door for new opportunities for services provided by ESSs.

6.2.2 Technology Breakthrough

One of the most important factors that were considered in the search for the best suitable ESSs for the SDP was the maturity of the technology. Plenty of research is today performed in the area of energy storage and especially in the area of batteries. With the main source, in terms maturity of ES technologies, from 2013 and the fact that the ESS might be installed in a few years, the maturity curve might have changed drastically and new technologies that today are considered to be in the development field, could provide a better choice than the current mature technologies at that time.

6.2.3 Limitation of Data and Model Used for Simulations

The model used for the OpenModelica simulations also constitutes a limitation of the thesis work. Firstly, the model actually started out as a more complex model than what was finally used. The fact that the simulations resulted in unreasonably large simulation periods in the beginning of the process, lead us to simplify the model. That is the reason why for example all resistances are removed and disregarded in the model. For a model more aligned with the real world, proper resistances based on internal and external grid infrastructure data would be needed.

For further simplification the ES unit in the model has been assumed to have 100 % in efficiency. Li-ion could reach a RTE close to 100 % but both NaS and Lead-acid batteries have their RTE interval around 75-85 %. As discussed earlier about arbitrage, a low RTE would lead to losses in when comparing the absorbed energy and the discharge energy, which our model does not take into account. A neglected RTE should not affect the dimension of the ESS significant, which makes the assumption to neglect it acceptable.

Also, the simplification to use a complete DC based model, translates to be a limitation of the thesis. The model does not account e.g. for impedances and reactive power that would occur in AC systems. Also losses in transformers and switchgear are disregarded.

Moreover, the ES unit is modelled in a very simple way in the simulation tool. The response time for the modelled unit is practically unlimited. However, since the calculated CPV outputs are sampled with a 1-minute resolution, any unreasonable response time for the ES should not be reached.

One limitation of the simulation output is the lack of information regarding the number and size of the individual charge and discharge events. This could pose to be valuable input for choosing the most optimal ES technology, regarding the depth of discharge and its relation to lifetime. This addition to the model had to be dropped due to time constraints.

6.2.4 Cost Intervals

One major uncertainty that fundamentally could change the capital cost and LCOE for the batteries is which sources that have been used to gather cost data and how these sources have performed their calculations. The LCOE is dependent on how the possible provided services are valued, the dimension of both the power and the energy of the ESS and where the storage is placed. All the three sources that laid the foundation to the table with the LCOE, presented at least two different scenarios of umbrella groups of services, which gave different intervals of LCOE. (Akhil, et al., 2015) provided the most detailed information where these two umbrella groups of services (transmission & distribution support services and bulk services) are divided in energy and power requirement. When only consider the average LCOE from these three sources there is always the problem that the result can be affected by the fact that a service that is not suitable for a certain technology is included in the calculation e.g. that the SoC of Lead-acid batteries reach below 20 %. This could give a very high LCOE because the lifetime would be shorter and this high cost would then affect the average cost. We have not in this thesis located the exact LCOE for the chosen services but instead included the LCOE for all kind of relevant services. The same method has been used for all batteries, which make the result valid to compare.

6.2.5 Data Errors and Sizing for Ramping Support

When dimensioning the ES for the ramping support service, one should keep in mind that undetected data errors could have a serious impact on the sizing outcome, probably more strongly than when dimensioning for other services. The problem arises from the fact that the ramping support service is dimensioned based on extreme differences between two output values. If the output is high and suddenly drops to a near-zero value, this could be an extreme ramp rate event, but it could potentially be a measurement or data error. This makes the sizing process for ramping support more sensitive to data errors. Furthermore, these data errors could be hard to distinguish from real events. A possible solution for this would be more than one measuring unit.

6.3 Follow up Research

Following this master thesis, a number of topics promise to be very interesting to look into for further research. An updated deeper analysis of the value of different provided ES services could compose a driving force for development and investments in this area. Also the field of regulation connected to energy storage and its service related component will be of increasing interest globally. Since CPV is a rather new technology, and small in scale compared to PV, variability studies specifically for CPV would be valuable for further discussions regarding synergies with energy storage. Lastly, the development of

smarter control strategies for all three of the treated surfaces could translate into smoother operation, longer lifetime, increased revenue and shorter payback for existing and future systems.

Follow up research on this specific report would be to investigate the value of different services for both Enercoutim for the DSO EDP. A very interesting approach would be that Enercoutim and EDP together develop an ES as a pilot project that could provide ground breaking results for the combination of CPV with an ESS.

7 Conclusion

It was found that an energy storage based on the sodium sulphur technology would be the preferred alternative. The proposed sizing was set at a rated power of 2.75 MW and an energy capacity of 1 MWh. With these characteristics, more than 98 % of the simulated extreme ramping events would be covered for. A general conclusion from the analysis is that to provide the service of ramping support, a rather high power rating is needed, while the required energy capacity is small. This means that out of the three chosen services, ramping support is the one dimensioning for the rated power. On the contrary, peak shaving and arbitrage are energy capacity intensive, thus, they are the services dimensioning the energy parameter. It was also found that the arbitrage service, with the chosen energy storage dimensions, resulted in very limited gains in revenue. However, when the service is combined with the peak shaving, it can instead be seen as a strategy to minimize losses in revenue.

Regarding technologies, it was early concluded that a mature option of battery energy storage was going to be chosen for our case. The sodium sulphur technology was found to excel, from an economical standpoint, in cases where the required energy capacity is rather large. The lithium ion technology on the other hand is preferred when this dimension is kept small. A lead-acid battery was found problematic to combine with the services of peak shaving and arbitrage because of its limited ability to be fully discharged.

Research on topic of energy storage is of major importance and value, especially at this point in time because of several reasons. The penetration of intermittent RES is steadily increasing, at the same time as ambiguous goals for limiting the use of (dispatchable) fossil fuelled power production are set up. The combination of these factors call upon the growing need for utility sized energy storage solutions, in order not to jeopardize grid stability and energy dispatchability. It is also clear that an investment in energy storage, for most of today's cases, has to be result in a multitude of provided grid and/or power producer-oriented services. That is why it is of great interest to find valuable synergies between energy storage technology, power production technology, and provided services.

Following this master thesis, a number of topics promise to be very interesting to look into for further research. An updated deeper analysis of the value of different provided ES services could compose a driving force for development and investments in this area. Also the field of regulation connected to energy storage and its service related component will be of increasing interest globally. Since CPV is a rather new technology, and small in scale compared to PV, variability studies specifically for CPV would be valuable for further discussions regarding synergies with energy storage. Lastly, the development of smarter control strategies for all three of the treated surfaces could translate into smoother operation, longer lifetime, increased revenue and shorter payback for existing and future systems.

The electrical energy system faces probably the biggest transition in its history, with the long-term aim of reaching fossil fuel independence. Energy storage will inevitably constitute a growing element in this future system. Progress in the area of energy storage will be accompanied with the development of new power production technologies. This poses a unique opportunity. If we challenge ourselves to find the smartest ways of combining these pieces of technology, the results will accelerate our journey towards a sustainable and brighter future.

8 References

- Zagoras, N. (2014). *Battery Energy Storage System (BESS): A Cost/Benefit Analysis for a PV power station*. Charleston: Clemson University Restoration Institute, SC.
- Zakeri, B., & Syri, S. (2014). *Electrical energy storage systems: A comparative life cycle cost analysis*. Aalto, Finland: Science Direct.
- Vasconcelos, J., Ruester, S., He, X., Chong, E., & Glachant, J.-M. (2012). *Electricity Storage: How to Facilitate its Deployment and Operation in the EU (Topic 8)*. THINK, European University Institute.
- ABB. (2016). *Storage Application*. Retrieved 05 24, 2016, from Peak Shaving: <http://new.abb.com/substations/energy-storage-applications/peak-shaving>
- Akhil, A. A., Huff, G., Currier, A. B., Kaun, B. C., Rastler, D. M., Chen, S. B., et al. (2015). *DOE/EPRI Electricity Storage Handbook in Collaboration with NRECA*. Albuquerque, New Mexico: Sandia National Laboratories.
- Antonio Luque, S. H. (2011). *Handbook of Photovoltaic Science and Engineering*. A John Wiley and Sons.
- Buchmann, I. (2016). *Battery University: Learn About Batteries: How does the Flow Battery Work?* Retrieved 03 18, 2016, from Battery University: http://batteryuniversity.com/learn/article/bu_210b_flow_battery
- Battery Council International. (2016). *Lead acid batteries*. Retrieved 04 18, 2016, from Battery Council International: http://batteryCouncil.org/?page=lead_acid_batteries
- Brains, D. (2012, 06 18). *Wikimedia Commons: Portugal location map Topographic*. Retrieved 06 19, 2016, from Wikimedia Commons: https://commons.wikimedia.org/wiki/File:Portugal_location_map_Topographic.png
- Curtright, A. E., & Apt, J. (2008). The Character of Power Output from Utility-Scale Photovoltaic Systems. *Progress in Photovoltaics*, 16 (3), 241–247.
- Cavaco et al. (2015). *DNI Measurements in the South of Portugal: Long Term Results through Direct Comparison with Global and Diffuse Radiation Measurements and Existing Time Series*. Évora: Universidade de Évora.
- California ISO. (2010). *Operational Requirements and Generation Fleet Capability at 20 % RPS*. Folsom.
- European Commission. (2011). *European Commission: Europe 2020 targets*. Retrieved 04 21, 2016, from European Commission: http://ec.europa.eu/europe2020/targets/eu-targets/index_en.htm
- European Commission. (2016a, 5 31). *Energy Union and Climate*. Retrieved from http://ec.europa.eu/priorities/energy-union-and-climate_en

European Commission. (2016, February). *Energy from renewable sources*. Retrieved 04 22, 2016, from European Commission: http://ec.europa.eu/eurostat/statistics-explained/index.php/Energy_from_renewable_sources

European Commission. (2015c). *Launching the public consultation process on a new energy market design*. Brussel: European Commission.

European Commission. (2015, May). *Renewable energy statistics*. Retrieved 04 22, 2016, from European Commission: http://ec.europa.eu/eurostat/statistics-explained/index.php/Renewable_energy_statistics

European Commission. (2015b). *The future role and challenges of Energy Storage*. Brussel: European Commission.

European Parliament. (2015). *Energy Storage: Which Market Designs and Regulatory Incentives Are Needed?* Policy department A - Economic and scientific policy. Brussel: European Parliament.

Exeter Associates Inc. (2007). *Review of International Experience Integrating Variable Renewable Energy Generation*. Columbia, Maryland: California Energy Commission.

EASE. (2016b). *EASE: Technology Description*. Retrieved 04 11, 2016, from European Association for Storage of Energy: Electrochemical Double Layer Capacitor: http://ease-storage.eu/wp-content/uploads/2016/03/EASE_TD_EDLC.pdf

EASE. (2016a). *Energy Storage Technologies*. Retrieved 06 09, 2016, from <http://ease-storage.eu/energy-storage/technologies/>

EEA. (2015). *Renewable energy in Europe — approximated recent growth and knock-on effects*. European Energy Agency.

Enercoutim. (2016a). *Enercoutim, ASSOCIAÇÃO EMPRESARIAL DE ENERGIA SOLAR DE ALCOUTI*. Retrieved 06 16, 2016, from <http://en.enercoutim.eu/>

Enercoutim. (2016b). *Plataforma de Demonstração Solar - Resumo Técnico*. Lisbon.

EPRI. (2013). *Cost-Effectiveness of Energy Storage in California*. Palo Alto, California: Electric Power Research Institute.

EPRI. (2010). *Functional Requirements for Electric Energy Storage Applications on the Power System Grid*. Palo Alto, USA: Electric Power Research Institute.

ESA. (2016a). *Energy Storage Association*. Retrieved 03 15, 2016, from Grid Operator Benefits: <http://energystorage.org/energy-storage/energy-storage-benefits/benefit-categories/grid-operations-benefits>

ESA. (2016b). *Energy Storage Association*. Retrieved 03 17, 2016, from End-User Benefits: <http://energystorage.org/energy-storage/energy-storage-benefits/benefit-categories/end-user-benefits>

ESA. (2016e). *Energy Storage: Compressed Air Energy Storage (CAES)*. Retrieved 03 18, 2016, from Energy Storage Association: <http://energystorage.org/compressed-air-energy-storage-caes>

ESA. (2016d). *Energy Storage: Flywheels*. Retrieved 03 17, 2016, from <http://energystorage.org/energy-storage/storage-technology-comparisons/thermal>

ESA. (2016f). *Energy Storage: Hydrogen Energy Storage*. Retrieved 04 13, 2016, from Energy Storage Association: <http://energystorage.org/energy-storage/technologies/hydrogen-energy-storage>

ESA. (2016c). *Energy storage: Pumped Hydro-Power*. Retrieved 03 16, 2016, from Energy Storage Association: <http://energystorage.org/energy-storage/energy-storage-technologies/pumped-hydro-power>

ESA. (2016g). *Technologies: Solid State Batteries - Electrochemical Capacitors*. Retrieved 04 11, 2016, from Energy Storage Association: <http://energystorage.org/energy-storage/technologies/electrochemical-capacitors>

ESA. (2016g). *Technologies: Solid State Batteries/Flow Batteries*. Retrieved 03 18, 2016, from Energy Storage Association: <http://energystorage.org/energy-storage/energy-storage-technologies>

Deutsche Bank. (2015). *Crossing the Chasm*. New York.

Decourt, B., & Debarre, R. (2013). *Electricity Storage Factbook*. SBC Energy Institute.

Decourt, B., & Debarre, R. (2013a). *Electricity Storage Factbook*. SBC Energy Institute.

Decourt, B., & Debarre, R. (2013b). *Electricity Storage Factbook*. SBC Energy Institute.

DOE. (2016b). *DOE Global Energy Storage Database*. Retrieved 04 11, 2016, from Global Project Installations Over Time: http://www.energystorageexchange.org/projects/data_visualization

DOE. (2016c, 2016). *DOE Global Energy Storage Database*. Retrieved 04 13, 2016, from DOE Global Energy Storage Database:
http://www.energystorageexchange.org/projects/advanced_search?utf8=%E2%9C%93&name_eq=&technology_type_sort_eqs%5B%5D=Electro-chemical&technology_type_sort_eqs%5B%5D=Electro-mechanical&size_kw_ll=1000&size_kw_ul=10000&kW=1%2C000+-+10%2C000+kW&rated_power=1

DOE. (2016a). *DOE Global Energy Storage Database: Advanced Search*. Retrieved 03 25, 2016, from DOE Global Energy Storage Database: <http://www.energystorageexchange.org/projects>

DOE. (2016b). *DOE Global Energy Storage Database: Advanced Search*. Retrieved 03 17, 2016, from DOE Global Energy Storage Database: http://www.energystorageexchange.org/projects/advanced_search ;
Data extracted with filters: Technology type: Electro-mechanical: Operational

DOE. (2016b). *DOE Global Energy Storage Database: Advanced Search*. Retrieved 03 17, 2016, from DOE Global Energy Storage Database:
http://www.energystorageexchange.org/projects?utf8=%E2%9C%93&technology_type_sort_eqs=Compr

essed+Air+Storage&technology_type_sort_eqs_category=Electro-mechanical&technology_type_sort_eqs_subcategory=Electro-mechanical%3ACompressed+Air+Storage&country_sort_eq=&state_sort_eq=&kW=&kWh=&service_use_case_inf=&ownership_model_eq=&status_eq=&siting_eq=&order_by=&sort_order=&search_page=1&size_kw_ll=&size_kw_ul=&size_kwh_ll=&size_kwh_ul=&show_unapproved=%7B%7D

DOE. (2016c). *DOE Global Energy Storage Database; Advanced Search*. Retrieved 03 18, 2016, from DOE Global Energy Storage Database: http://www.energystorageexchange.org/projects/advanced_search; Filters: Electro-chemical, Operational, Prim/Sec Distribution and Transmission

Fraunhofer ISE. (2016, March 11). *Fraunhofer ISE; Downloads; Photovoltaics Report In Englischer Sprache*. Retrieved April 26, 2016, from Fraunhofer ISE: <https://www.ise.fraunhofer.de/de/downloads/pdf-files/aktuelles/photovoltaics-report-in-englischer-sprache.pdf>

GeoModel Solar. (2014). *Solargis - Maps of Direct normal irradiation (DNI)*. Retrieved 03 07, 2016, from Solargis: <http://solargis.info/doc/free-solar-radiation-maps-DNI#T>

GTM research. (2015). *U.S. Energy Storage Monitor: Q3 2015 Executive Summary*. gtm research.

IEA. (2015a, November 10). *World Energy Outlook*. Retrieved April 21, 2016, from World Energy Outlook: Home: <http://www.worldenergyoutlook.org/>

IEA. (2015b). *World Energy Outlook Special Report 2015: Energy and Climate Change*. Paris: IEA.

IEA. (2016). *Energy Policies of IEA Countries - Portugal - 2016 Review*. Paris: International Energy Agency.

IEA. (2014b). *Energy Supply Security 2014. Part 2, Chapter 4: Portugal*. IEA.

IEA. (2015a). *Energy Technology Perspectives 2015 - Mobilising Innovation to Accelerate Climate Action*. International Energy Agency.

IEA. (2012). *International Energy Statistics*. Retrieved 03 16, 2016, from <https://www.eia.gov/cfapps/ipdbproject/IEDIndex3.cfm?tid=2&pid=2&aid=7>

IEA. (2014). *Technology Roadmap - Energy Storage*. Paris: International Energy Agency.

IEC. (2012). *Electric Energy Storage*. Geneva: International Electrotechnical Commission.

IRENA. (2015). *Case studies: battery storage*. IRENA.

IRENA. (2012). *Electrical Storage and Renewable for Island Power - A Guide for Decision Makers*. Abu Dhabi: International Renewable Energy Agency.

IRENA. (2013). *Smart Grids and Renewables*. Abu Dhabi: International Renewable Energy Agency.

IRENA. (2014). *Technology Roadmap*. Paris, France: International Energy Agency.

Haaren, R. (2014). *Utility Scale Photovoltaic Plant Variability Studies and Energy Storage Optimization for Ramp Rate Control*. New York: Colombia University.

Haaren, R. v. (2014a). *Utility Scale Photovoltaic Plant Variability and Energy Storage Optimization for Ramp Rate Control*. Columbia University. Rob van Haaren.

Hansen, T. N. (2007). *Utility Solar Generation Valuation Methods*. DOE.

Hill, C., & Chen, D. (2012). *The University of Texas at Austin - Mechanical Engineering*. Retrieved 05 12, 2016, from The University of Texas at Austin: <https://www.me.utexas.edu/~apscl/pdf/GAIN%20-%20Hill.pdf>

Kurzweil, P. (2015). Lithium Battery Energy Storage: State of the Art Including Lithium–Air and Lithium–Sulfur Systems. In P. T. Moseley, & J. Garche, *Electrochemical Energy Storage for Renewable Sources and Grid Balancing* (pp. 269–307). Amsterdam: Elsevier.

Larsson, Ö., & Ståhl, B. (2012). *Lösningar på Lager - Energilagringstekniken och framtidens hållbara energiförsörjning*. Blue Institute. Stockholm: VINNOVA.

LightSail Energy. (2016). *LightSail Energy: Homepage*. Retrieved 03 18, 2016, from LightSail Energy: <http://www.lightsail.com/>

Linden, D., & Reddy, T. B. (2002). *Handbook of Batteries (3rd ed.)*. New York: McGraw-Hill.

Nykamp, S., Molderink, A., Hurink, J. L., & Smit, J. M. (2013). *Storage Operation for Peak Shaving of Distributed PV and Wind Generation*. New Jersey: Institute of Electrical and Electronics Engineers.

Navigant Research. (2014). *Community, Residential, and Commercial Energy Storage*. Navigant Research.

Norris, B. L., & Dise, J. H. (2013). *High Resolution PV Power Modeling for Distribution Circuit Analysis*. Golden: National Renewable Energy Laboratory.

NREL. (2016). *Current Status of Concentrator Photovoltaic (CPV) Technology*. Golden, Colorado, USA: National Renewable Energy Laboratory NREL.

Malhotraa, A., BattkeB, B., Beuseb, M., Stephanb, A., & Schmidta, T. (2015). *Use cases for stationary battery technologies: A review of the literature and existing projects*. Zurich: Science Direct.

Marcos, J., Marroy, L., Lorenzo, E., & García, M. (2012). *Power output fluctuations in large PV plants*. EA4EPQ.

Marcos, J., Storkel, O., Marroyo, L., Garcia, M., & Lorenzo, E. (2014). Storage requirements for PV power ramp-rate control. *Solar Energy*, 99, 28-35.

Marcos, J., Storkel, O., Marroyo, L., Garcia, M., & Lorenzo, E. (2014). *Storage requirements for PV power ramp-rate control*. Madrid: Science Direct.

- McKeon, B. B., Furukawa, J., & Fenstermacher, S. (2014). Advanced Lead–Acid Batteries and the Development of Grid-Scale Energy Storage Systems. *Proceedings of the IEEE* , 102, 951-963.
- Moseley, P. T., & Rand, D. A. (2015). High-Temperature Sodium Batteries for Energy Storage. In P. T. Moseley, & J. Garche, *Electrochemical Energy Storage for Renewable Sources and Grid Balancing* (pp. 253–268). Amsterdam: Elsevier.
- Palizban & Kauhaniemi. (2016c, Feb 2). Energy storage systems in modern grids—Matrix of technologies and applications. *Journal of Energy Storage* , 4.
- Palizban, O., & Kauhaniemi, K. (2016a, Feb 2). Energy storage systems in modern grids—Matrix of technologies and applications. *Journal of Energy Storage* , 8.
- Palizban, O., & Kauhaniemi, K. (2016b, feb 2). Energy storage systems in modern grids—Matrix of technologies and applications. *Journal of Energy Storage* , 9.
- Palizban, O., & Kauhaniemi, K. (2016c, Feb 2). Energy storage systems in modern grids—Matrix of technologies and applications. *Journal of Energy Storage* , 4.
- Philipps, S. P., & Bett, A. W. (2016). *CURRENT STATUS OF CONCENTRATOR PHOTOVOLTAIC (CPV) TECHNOLOGY*. Fraunhofer Institute for Solar Energy Systems ISE. Freiburg: Fraunhofer ISE.
- Subburaj, Pushpakaran, Bayne, A. (2015). *Overview of grid connected renewable energy based battery projects in USA*. Lubbock, Texas: Department of Electrical and Computer Engineering, Texas Tech University.
- Sumitomo Electric Industries, Ltd. (2014, 04 7). *Sumitomo Electric: Press Release 2014*. Retrieved 06 19, 2016, from Sumitomo Electric: http://global-sei.com/news/press/14/prs025_s.html
- SustainX. (2016). *Technology: Isothermal CAES*. Retrieved 03 18, 2016, from SustainX Web site: <http://www.sustainx.com/technology-isothermal-caes.htm>
- SBC Energy Institute. (2010b). *Electricity Energy Storage Options*. EPRI.
- SBC Energy Institute. (2010a). *ENERGY STORAGE TECHNOLOGY REVIEW*. SBC ENERGY INSTITUTE ANALYSIS BASED ON KYLE BRADBURY.
- Sengupta, M. (2011). *Measurement and Modeling of Solar and PV Output Variability*. NREL.
- Service, R. F. (2015, 11 27). New type of ‘flow battery’ can store 10 times the energy of the next best device. *Science* .
- SolarGIS. (2015, 06 07). *Free Download of Solar Radiation Maps: Direct Normal Irradiation (DNI)*. Retrieved from <http://solargis.info/doc/free-solar-radiation-maps-DNI>

Rand, D. A., & Moseley, P. T. (2015). Chapter 13 – Energy Storage with Lead–Acid Batteries. In P. T. Moseley, & J. Garche, *Electrochemical Energy Storage for Renewable Sources and Grid Balancing* (pp. 201-222). Amsterdam: Elsevier.

REN. (2012). *Redes Energéticas Nacionais*. Retrieved 03 17, 2016, from The Electricity Sector:
http://www.ren.pt/en-GB/o_que_fazemos/eletricidade/o_setor_eletrico/

REN. (2016). *REN: MIBEL Precos - Preco Mercado Spot - Portugal e Espanha*. Retrieved 06 04, 2016, from REN: Sistema de Informacao de Mercados de Energia:
www.mercado.ren.pt/PT/Electr/InfoMercado/InfOp/MercOmel/Paginas/Precos.aspx

RMI. (2015). *The Economics of Battery Energy Storage*. Denver: Rocky Mountain Institute.

RMI. (2015). *The Economics of Battery Energy Storage*. Boulder, USA: Rocky Mountain Institute.

9 Appendix

9.1 Appendix A

Appendix A consists of assumptions and formulas that lay the foundation to the LCOE.

$$CRF = \frac{i(1+i)^T}{(1+i)^T - 1}$$

$$C_{cap,a} = TCC * CRF$$

$$C_{O\&M,a} = C_{FOM,a} + C_{VOM} * n * h$$

$$C_{R,a} = CRF * \sum_{k=1}^T (1+i)^{-kt} * \left(\frac{C_R * h}{n_{sys}}\right)$$

$$C_{DR,a} = C_{DR} * \frac{i}{(1+i)^T - 1}$$

$$C_{LCC,a} = C_{cap,a} + C_{O\&M,a} + C_{R,a} + C_{DR,a}$$

$$LCOE = \frac{C_{LCC,a}}{n * h}$$

Table 9-1. The currency exchange rate for USD to EUR for five different years.

Currencies, EUR and USD	USD	EUR
2012	1.00	1.25
2013	0.95	1.26
2014	1.04	1.33
2015	1.21	1.37
Until the 1 of June 2016.	1.21	1.36

Table 9-2. Calculation of how the USD and EUR from different years were calculated to EUR with the exchange rate of 2016.

Report	Currency	USD to EUR	EUR 201x to EUR 2016	Value in table
IRENA 2012	USD	1.00/1.25≈0.80	1.25/1.36≈0.92	LCOE*0.80*0.92=table
Zakeri & Syri, 2014	EUR	-	1.33/1.36≈0.98	LCOE*0.98=table
SANDIA 2015	USD	1.21/1.37≈0.89	1.36/1.37≈1.00	LCOE*0.89*1.00=table

9.2 Appendix B

Appendix B consists of specifications and translations of services and technologies that have been used in order to make the thesis easier to read when different sources have been compared.

Table 9-3. Translation on different names for the same kind of service. Akhil et al. classification is used during this report.

Service (Global Energy Storage Database)	SANDIA
RE smoothing/ramping	Load Following/Ramping support for RE (Ancillary Service)
Frequency	Frequency respond (Ancillary service)
Renewables Capacity Firming	Load Following/Ramping support for RE (Ancillary Service)
Ramping	Load Following/Ramping support for RE (Ancillary Service)
Electric Energy Time Shift	Electric Energy Time Shift (arbitrage) (Bulk Service)
Onsite Renewable Generation Shifting	Retail Electric Energy Time-Shift (Customer Service)

9.3 Appendix C

Appendix C consists of parameters and code used in the control units, calculator and one PID-regulator in the simulation model. The code is in line with the model and process flow chart presented in chapter 4 “Design method”.

S-controller

Parameters

```
S_start = 0;           //kWh
S_full = 1000;         //kWh
S_empty = 0;
S_mid = (S_full + S_empty)/2;
```

Code

```
model Storage_Controller
parameter Real S_start = 0 "kWh";
parameter Real S_full = 50 "kWh";
parameter Real S_empty = 10 "help";
parameter Real S_mid = (S_full + S_empty) / 2;
//parameter Real S_ref_low1 = 0.95 "help";
//parameter Real S_ref_low2 = 0.9 "help";
//Real u_ref "help";
Boolean s_high "help";
Boolean s_low "help";
Boolean s_under_mid;
Boolean s_tryingLoad;
Boolean s_tryingUnload;
Modelica.Blocks.Interfaces.RealInput u2 annotation(Placement(visible = true, transformation(origin = {-120, 0}, extent = {{-20, -20}, {20, 20}}, rotation = 0), iconTransformation(origin = {-106, 0}, extent = {{-20, -20}, {20, 20}}, rotation = 0)));
```

```

Modelica.Blocks.Interfaces.RealOutput y annotation(Placement(visible = true, transformation(origin
= {0, -110}, extent = {{-10, -10}, {10, 10}}, rotation = -90), iconTransformation(origin = {0, -110},
extent = {{-10, -10}, {10, 10}}, rotation = -90)));
Modelica.Blocks.Interfaces.RealInput u1 annotation(Placement(visible = true, transformation(origin
= {120, 0}, extent = {{20, -20}, {-20, 20}}, rotation = 0), iconTransformation(origin = {106, 0}, extent
= {{20, -20}, {-20, 20}}, rotation = 0)));
Modelica.Blocks.Interfaces.RealOutput y1 annotation(Placement(visible = true,
transformation(origin = {62, -110}, extent = {{-10, -10}, {10, 10}}, rotation = -90),
iconTransformation(origin = {72, -110}, extent = {{-10, -10}, {10, 10}}, rotation = -90)));
equation
s_high = S_start + u2 > S_full;
s_low = S_start + u2 < S_empty;
s_under_mid = S_start + u2 < S_mid;
s_tryingLoad = u1 < 0;
s_tryingUnload = u1 > 0;
y = if s_high and s_tryingLoad or s_low and s_tryingUnload then 0 else u1;
when s_high or s_under_mid then
y1 = if s_high then 1.0 else -1.0;
end when;
//ExternUnload = if edge(s_high) and not edge(u2 < S_mid) then 1 else -1;
annotation(Diagram(coordinateSystem(extent = {{-100, -100}, {100, 100}}, preserveAspectRatio =
true, initialScale = 0.1, grid = {2, 2})), Icon(coordinateSystem(extent = {{-100, -100}, {100, 100}},
preserveAspectRatio = true, initialScale = 0.1, grid = {2, 2}), graphics = {Rectangle(lineThickness = 1,
extent = {{-100, 100}, {100, -100}}), Text(origin = {2, 1}, extent = {{-48, -17}, {48, 17}}, textString =
"S-controller"))));
end Storage_Controller;

```

Energy_calc

A input value to this calculator is the standard OpenModelica class Continuous.Integrator.

Code

```

model Energy_calc
Real energy_Ws;
Real energy_kWh;
Real energy_pos;
Modelica.Blocks.Interfaces.RealInput u1 annotation(Placement(visible = true, transformation(origin
= {-120, 0}, extent = {{-20, -20}, {20, 20}}, rotation = 0), iconTransformation(origin = {-106, 0},
extent = {{-20, -20}, {20, 20}}, rotation = 0)));
Modelica.Blocks.Interfaces.RealOutput y annotation(Placement(visible = true, transformation(origin
= {-50, -110}, extent = {{-10, -10}, {10, 10}}, rotation = -90), iconTransformation(origin = {-50, -110},
extent = {{-10, -10}, {10, 10}}, rotation = -90)));
Modelica.Blocks.Interfaces.RealOutput y1 annotation(Placement(visible = true,
transformation(origin = {50, -110}, extent = {{-10, -10}, {10, 10}}, rotation = -90),
iconTransformation(origin = {50, -110}, extent = {{-10, -10}, {10, 10}}, rotation = -90)));
equation
energy_Ws = -u1;

```

```

energy_kWh = -u1 / (1000 * 3600);
y = energy_Ws;
y1 = energy_kWh;
energy_pos = energy_kWh + 244;
annotation(Diagram(coordinateSystem(extent = {{-100, -100}, {100, 100}}, preserveAspectRatio =
true, initialScale = 0.1, grid = {2, 2})), Icon(coordinateSystem(extent = {{-100, -100}, {100, 100}},
preserveAspectRatio = true, initialScale = 0.1, grid = {2, 2}), graphics = {Rectangle(lineThickness = 1,
extent = {{-100, 100}, {100, -100}}), Text(origin = {2, 1}, extent = {{-48, -17}, {48, 17}}, textString =
"Energy-calc")}), experiment(StartTime = 0, StopTime = 25000, Tolerance = 0.0001, Interval = 5));
end Energy_calc;

```

Ramp-rate ready G-controller (Former G-controller according to the model in chapter 4)

Parameters

```

E_buffer = 0;           //Energy buffer level that the ES should have during daytime operation
(kWh)
yDerMax = 7.5;         //Systemwide yDerMax (maximum Ramp Rate) (kW/s)
P_arb = 3750000;       //Only for show in diagram

```

Code

```

model Grid_Controller_RRready
parameter Real E_buffer = 10 "Energy buffer level that the ES should have during daytime operation
(kWh)";
parameter Real yDerMax = 1 "Systemwide yDerMax (maximum Ramp Rate) (kW/s)";
parameter Real P_arb = 3750000 "Only for show in diagram";
Real E_es "Energy level of ES (Ws)";
Real E_rd "Energy required for Ramp Down (Ws)";
Real E_tot "Energy for Ramp Down plus E_buffer (Ws)";
Real toWs = 1000 * 3600;
Real u2_stat;
Modelica.Blocks.Interfaces.RealInput u2 annotation(Placement(visible = true, transformation(origin
= {-120, 0}, extent = {{-20, -20}, {20, 20}}, rotation = 0), iconTransformation(origin = {-106, 0},
extent = {{-20, -20}, {20, 20}}, rotation = 0)));
Modelica.Blocks.Interfaces.RealOutput y annotation(Placement(visible = true, transformation(origin
= {0, -110}, extent = {{-10, -10}, {10, 10}}, rotation = -90), iconTransformation(origin = {0, -110},
extent = {{-10, -10}, {10, 10}}, rotation = -90)));
Modelica.Blocks.Interfaces.RealInput u1 annotation(Placement(visible = true, transformation(origin
= {120, 0}, extent = {{20, -20}, {-20, 20}}, rotation = 0), iconTransformation(origin = {106, 0}, extent
= {{20, -20}, {-20, 20}}, rotation = 0)));
equation
// u1 = ES Energy level (Ws)
// u2 = CPV Output (W)
E_es = u1;
E_rd = u2 ^ 2 / (2 * yDerMax * 1000);
E_tot = E_rd + E_buffer * toWs;
when E_es < E_tot then

```

```

u2_stat = pre(u2);
end when;
y = if E_es < E_tot then u2_stat else u2;
annotation(Diagram(coordinateSystem(extent = {{-100, -100}, {100, 100}}, preserveAspectRatio =
true, initialScale = 0.1, grid = {2, 2})), Icon(coordinateSystem(extent = {{-100, -100}, {100, 100}},
preserveAspectRatio = true, initialScale = 0.1, grid = {2, 2}), graphics = {Rectangle(lineThickness = 1,
extent = {{-100, 100}, {100, -100}}), Text(origin = {2, 1}, extent = {{-48, -17}, {48, 17}}, textString =
"G-Controller"), Text(origin = {-15, 31}, extent = {{-51, 15}, {79, -11}}, textString = "Ramp-rate
ready"))});
end Grid_Controller_RRready;

```

Arbitrage

Parameters

```

P_arb = 500000; //Maximum Power for Arbitrage service (W)
Selling_price = 65; //Minimum selling price (Euro/kWh)
Charge_price = 0; //Maximum el. price when energy will be stored instead of sold (Euro/kWh)
E_limit_min = 10; //Selling energy in storage until this level (kWh)
E_limit_max = 0; //Will not charge higher than this ES energy level (kWh)
yDerMax = 7.5;

```

Code

```

model Grid_Controller_arb4
parameter Real P_arb = 0 "Maximum Power for Arbitrage service (W)";
parameter Real Selling_price = 65 "Minimum selling price (Euro/kWh)";
parameter Real Charge_price = 50 "Maximum el. price when energy will be stored instead of sold
(Euro/kWh)";
parameter Real E_limit_min = 1 "Selling energy in storage until this level (kWh)";
parameter Real E_limit_max = 5000 "Will not charge higher than this ES energy level (kWh)";
parameter Real yDerMax = 7.5;
Real E_rd "Energy required for ramp down from P_arb (Ws)";
Real toWs = 1000 * 3600 "Used to convert kWh to Ws";
Boolean Grid_controll;
Boolean Good_energy;
Boolean Good_price;
Boolean OK_price;
Boolean ES_full;
Modelica.Blocks.Interfaces.RealInput u2 annotation(Placement(visible = true, transformation(origin
= {-120, 0}, extent = {{-20, -20}, {20, 20}}, rotation = 0), iconTransformation(origin = {-106, 0},
extent = {{-20, -20}, {20, 20}}, rotation = 0)));
Modelica.Blocks.Interfaces.RealOutput y annotation(Placement(visible = true, transformation(origin
= {0, -110}, extent = {{-10, -10}, {10, 10}}, rotation = -90), iconTransformation(origin = {0, -110},
extent = {{-10, -10}, {10, 10}}, rotation = -90)));
Modelica.Blocks.Interfaces.RealInput u1 annotation(Placement(visible = true, transformation(origin
= {120, 0}, extent = {{20, -20}, {-20, 20}}, rotation = 0), iconTransformation(origin = {106, 0}, extent
= {{20, -20}, {-20, 20}}, rotation = 0)));

```

```

Modelica.Blocks.Interfaces.RealInput u annotation(Placement(visible = true, transformation(origin
= {0, 120}, extent = {{-20, -20}, {20, 20}}, rotation = -90), iconTransformation(origin = {0, 108},
extent = {{20, -20}, {-20, 20}}, rotation = 90)));
equation
// u = Stored energy in battery (Ws)
// u1 = G-controller (W)
// u2 = El. price (Euros/kWh)
E_rd = P_arb ^ 2 / (2 * yDerMax * 1000);
Grid_controll = u1 > 1000 "True if G-controller is active";
OK_price = u2 > Charge_price "True if el. price is above the charge price";
Good_energy = u > E_limit_min * toWs + E_rd "True if battery has energy higher than limit AND
enough energy for ramp down";
Good_price = u2 > Selling_price "True if price signal is higher than minimum selling price";
ES_full = u > E_limit_max "True if ES is full";
y = if Grid_controll and OK_price or Grid_controll and ES_full then u1 else if Good_energy and
Good_price then P_arb else 0;
annotation(Diagram(coordinateSystem(extent = {{-100, -100}, {100, 100}}, preserveAspectRatio =
true, initialScale = 0.1, grid = {2, 2})), Icon(coordinateSystem(extent = {{-100, -100}, {100, 100}},
preserveAspectRatio = true, initialScale = 0.1, grid = {2, 2}), graphics = {Rectangle(lineThickness = 1,
extent = {{-100, 100}, {100, -100}}), Text(origin = {2, 1}, extent = {{-48, -17}, {48, 17}}, textString =
"Arbitrage")}), experiment(StartTime = 0, StopTime = 1278, Tolerance = 0.0001, Interval =
0.3195));
end Grid_Controller_arb4;

```

PID

Parameters

```

controllerType = Modelica.Blocks.Types.SimpleController.PID
k = 5;           //Gain of controller
yDerMax = 7.5;  //
Ti = 1000000;   //Time constant of Integrator block
Td = 0;         //Time constant of Derivative block
yMax = 3750;    //Upper limit of output

```